

### TWO-STROKE HIGH PERFORMANCE ENGINE DESIGN & TUNING

By World famous engine designer Bossaglia who was responsible for most of the Italian rotary valve kart engines including Komets and Parillas from the very first—the V11 to the R39. 227 pages packed with information including: Characteristics and types of two-stroke motors, Multi-cylinder engines, Fuel, Quantity of air necessary for combustion, Determining the power, The Pressure Volume diagram, Performance, The operation of the crank, Balance, The Stroke/bore ratio, Third port induction, Induction through valves, Blade type valves, Cylindrical rotary valves, Rotating disc valves, Transfer and scavenging with transverse flow, tangential flow, uni-directional flow, Counter-flow scavenging, Position of the ports, Bi-metal cylinders, Cylinders with chromed bore, The piston, The gudgeon pin, The piston rings, Constructional ideas for the piston, The head, The crankcase, The crankshaft, Modification of the crank shaft assembly, Modification of cylinder, piston and head, The carburettor, Fuel pumps, Carburettor adjustments, Fuel injection, The magneto, The sparking plug, Ignition timing, Electronic ignition, Lubrication, Exhaust System, Mufflers, Exhaust system for multi-cylinder engines, Exhaust silencers, Test procedure, Examples of modifications. £4.35 (incl. insurance) Ref 290

### ABOUT KART RACING

#### STARTING KARTING

How to start the sport explained, details of classes, location of tracks, British clubs and addresses, Where to buy karts, engines & accessories. 4th Edn. 50p. Ref 286

#### GOING KARTING

Covers every aspect of karting, how to buy your kart and engine, racing on motor tracks, etc. 4th Edn. £1.45. Ref 260

#### R.A.C. KART REGS 1974

All the rules and regulations governing drivers, organizers, tracks, karts and engines. British calendar of events, club addresses and list of tracks. 50p. Ref 130

**LODGE MARK PRESS LTD**  
BANK HOUSE, SUMMERHILL, CHISLEHURST,  
KENT BR7 5RD, ENGLAND

### TWO STROKES & TUNING

#### TWO-STROKE EXHAUST SYSTEMS

Full details on how to calculate design and make competition exhaust systems. 56p. Ref 252. Available again March

#### TWO-STROKE PORTS FOR POWER

Read how to calculate and design the right port timing for your requirements. 56p. Ref 253.

#### TWO-STROKE CARBURATION AND IGNITION

Roy Bacon's third book on racing two-strokes. Vital information on carburation & ignition. 58p. Ref 281

#### ROTARY VALVE TWO-STROKE KART ENGINES

All about 100cc kart engines. Includes Ariaco, R.M., Corsari, Farnet, Komet, Parilla, Petri, Saetta, Starr, Bassi preparations, using Bleepers, Transistorised ignition, Titanium carbs. £1.10. Ref 288

#### IMPROVING TWO STROCK ENGINE PERFORMANCE

Villiers, Malco, Vespa, Marchi, Zundapp, Ikon, DAW, Lambretta. 98p. Ref 138

### BUILDING KARTS

#### KARTING FOR SCHOOLS & YOUTH GROUPS

Organising, driving and building low-cost karts. Forming clubs. 90p. Ref 292

#### JAVELIN SET No. 1

Details and drawings to build a low price kart without a tube bender. Suitable for 2 or 4-stroke engines without gears, max 8 hp & 40 lbs for Cadet racing, fun and driver training. Bolted construction. 50p. Ref 270

#### CADET SET No. 2

Details and drawings to make a fun kart without a tube bender. Suitable for 2 or 4 stroke engines without a gearbox up to 8 hp and weighing up to 40 lbs. New edition provides option of bolted or welded construction. Any parts can be purchased if required. £1.10. Ref 293



### SERVICE AND OVERHAUL MANUAL FOR THE

# AJS & MATCHLESS SINGLE MOTORCYCLES

by

F. NEILL

Covering 1958 to 1964 Lightweight 250 c.c. and 350 c.c. models G2 G2S G2CS G2CSR 14 14S 14CS 14CSR G5 8 and 1957 to 1966 Heavyweight 350 c.c., 500 c.c. and 600 c.c. models G3 G3C G3S G3LS G3LCS G80 G80S G80CS TCS 16 16S 16C 16CS 16MS 16MC 16MCS 18 18S 18CS



**SERVICE AND OVERHAUL MANUAL  
FOR THE  
AJS & MATCHLESS  
SINGLE MOTORCYCLES**

by

**F. NEILL**

S.B.N. 850770203

Technical details, together with working instructions given in ensuing chapters are solely confined to the single cylinder A.J.S. and Matchless models, which are similar regarding design, and identified by the petrol tank emblems and colour finish. The engine design of the heavyweight single cylinder models is basically identical since 1948, and in consequence the engine assembly instructions—in the main—apply to all models made from 1948 to 1966. The lightweight models were introduced in 1959 and design changes with minor modifications are described to enable owners to incorporate the later parts into earlier engines, if so desired.

As the crankcases for the 350 and 500 heavyweight engines are identical since 1948—the small capacity engine can be converted to the larger type by substituting parts in the top portion of the engine.

*The author and the publishers wish to express their thanks to Norton Villiers Ltd. for their co-operation in the preparation of this book and permission to publish the text and illustrations.*

EDITOR H. A. NIMMO

© LODGEMARK PRESS LIMITED  
Bank House, Susan Wood, Chislehurst  
Kent BR7 5RD, England

## Contents

	page
Technical data	5
Engine design changes	13
Lubrication	18
Recommended lubricants	20
Periodical maintenance	21
Engine servicing	23
Engine overhaul	35
Gearbox and Clutch	54
Front forks ...	71
Rear suspension units	84
Frame	85
Wheel bearings	87
Wheels and Brakes	90
Transmission	100
Carburettor ...	102
Wipac alternator	104
Wipac electrical service	107
Lucas electrical service	111
Lucas coil ignition	112
Magneto	113
Dynamo	114
Wiring diagrams	120

## TECHNICAL DATA 250 c.c. G2 and G2S Models

<b>Identity</b>	
Engine Number	On the crankcase near engine plate cowling.
Frame Number	On right hand side of frame head lug.
Cylinder Bore	69.85 mm.
Stroke	64.84 mm.
Cubic Capacity	248.5 c.c. (15.2 cu. ins.)
<b>Carburettor</b>	
Type 376/99	Amal Monobloc (12° inclination)
Main jet (without air filter)	180
Main jet (with air filter)	180
Choke size	1 $\frac{1}{16}$ "
Throttle slide	3 $\frac{1}{2}$
Needle position	central (.106) pilot 25
<b>Capacities</b>	
Petrol tank	3 $\frac{1}{2}$ gallons (12.5 litres)
Oil capacity	2 $\frac{1}{2}$ pints (1.4 litres)
Gear box	3 pints (1.8 litres)
Front chain case	568 c.c.
<b>Compression Ratio</b>	7.8 to 1
<b>General</b>	
Seat height	30" (76 cms.)
Wheelbase	53" (134.5 cms.)
Weight	325 lbs. (148 kilos)
Ground clearance	5 $\frac{1}{2}$ " (14 cms.)
<b>Cylinder bore</b>	
Nominal size	2.7500 + .0005" - .0005"
<b>Piston Size</b>	
Skirt diameter (taken at right angle to gudgeon pin top of the skirt).	
High limit	2.7488"
Low limit	2.7480"

## 250 c.c. CSR 1962/64 Models

<b>Compression Ratio</b>	8 to 1
Valve springs (Scrambler Type)	Spring free length 1 $\frac{1}{2}$ " between wire centres.
<b>Inlet Valve head diameter (New Type)</b>	1 $\frac{19}{32}$ "
<b>Gear Ratios</b>	
Top	6.39 to 1
Third	8.31 to 1
Second	11.82 to 1
First	18.68 to 1

**Sprocket Sizes**

Engine	22 teeth
Gear box	18 teeth
Clutch	46 teeth
Rear Wheel	55 teeth

**Chain Sizes**

Front	Duplex .315 × .638" (72 links)
Rear	$\frac{1}{2}$ " × .305" (124 links)

**Carburettor**

Main jet	Type 389/82 ( $1\frac{1}{8}$ " bore)
Pilot jet	Size 200
Throttle slide	Size 30
Needle jet	3
Needle location	Size .106"
Spark Plug	Central notch
	FE 80

**250 c.c. CSR 1965/66 Models****Compression Ratio**

9.5 to 1

**Ignition Timing**24 degrees ( $\frac{1}{4}$ " full advance)**Valve spring (coil type)**inner free length 1.531"  
outer free length 1.700"**Gear Ratios***Internal Ratios*

Top	1 to 1
Third	1.24 to 1
Second	1.75 to 1
First	2.76 to 1

*Actual Ratios*

Top	6.5 to
Third	8.05 to
Second	11.68 to
First	17.97 to 1

**Spark Plug**

K.L.G. FE 220

**Piston Rings***Compression rings*

Diameter	$2\frac{3}{4}$ " (69.85 mm.)
Width	.0625"-.0615"
Radial Thickness	.112"—.106"

*Scraper ring*

Diameter	$2\frac{3}{4}$ " (69.85 mm.)
Width	.156"-.155"
Radial Thickness	.112"—.106"
Piston Ring Gap	.008"—.013"

**Valve Timing**

Inlet valve opens	40° B.T.D.C. with .010" rocker
Exhaust valve closes	40° A.T.D.C. clearance.

**Chain Sizes**

Front chain	$\frac{3}{8}$ " × .225" (73 links)
Rear chain	$\frac{1}{4}$ " × .305" (125 links)

**Gear Ratios***Internal Ratios*

Top	1 to 1
Third	1.30 to 1
Second	1.85 to 1
First	2.92 to 1

*Actual Ratios*

Top	6.89 to 1
Third	8.96 to 1
Second	12.75 to 1
First	20.12 to 1

**Sprocket Sizes**

Engine	21 teeth
Clutch	50 teeth
Final drive	19 teeth
Rear wheel	55 teeth

**350 c.c. Lightweight Model****Identity**

Engine number	On the crankcase near engine plate cowling.
Frame number	On right hand side of frame head lug.

**Cylinder bore**

72 mm.

**Stroke**

85.5 mm.

**Cubic capacity**

347 c.c. (21.17 cu. ins.)

**Carburettor**

Type 389/42

Main jet (without air filter)

220

Main jet (with air filter)

220

Choke size

 $1\frac{1}{8}$ "

Throttle slide

 $3\frac{1}{2}$ 

Needle position

central (.106) pilot 25

**Capacities**

Petrol tank

 $3\frac{1}{4}$  gallons (12.5 litres)

Oil capacity

 $2\frac{1}{2}$  pints (1.4 litres)

Gear box

3 pints (1.8 litres)

Front chain case

568 c.c.

**Compression Ratio**

6.9 to 1

**General**

Seat height

29.5" (74 cms.)

Wheelbase

53" (134.5 cms.)

Weight

340 lbs. (154 kilos)

Ground clearance

6" (15 cms.)

**Cylinder bore**

Nominal size

2.8345 + .0005" - .0005"

<b>Piston Size</b>	
Skirt diameter (taken at right angle to gudgeon pin top of the skirt).	
High limit	2.8286"
Low limit	2.8276"
<b>Piston Rings</b>	
<i>Compression rings</i>	
Diameter	72 mm.
Width	$\frac{3}{16}$ "
Radial Thickness	.151"—.109"
<i>Scraper ring</i>	
Diameter	72 mm.
Width	$\frac{5}{16}$ "
Radial Thickness	.109"—.101"
Piston Ring Gap	.008"—.013"
Ignition Timing	$\frac{1}{4}$ " B.T.D.C.
<b>Valve Timing</b>	
Inlet valve opens	40° B.T.D.C. with .010" rocker
Exhaust valve closes	40° A.T.D.C. clearance.
<b>Spark Plug</b>	K.L.G. FE 80
<b>Chain Sizes</b>	
Front chain	.315" × .628" Duplex (72 links)
Rear chain	$\frac{1}{2}$ " × .305" (123 links)
<b>Gear Ratios</b>	
<i>Internal Ratios</i>	
Top	1 to 1
Third	1.30 to 1
Second	1.85 to 1
First	2.92 to 1
<i>Actual Ratios</i>	
Top	6.39 to 1
Third	8.32 to 1
Second	11.82 to 1
First	18.68 to 1
<b>Sprocket Sizes</b>	
Engine	22 teeth
Clutch	46 teeth
Final drive	18 teeth
Rear wheel	55 teeth

### 350 c.c. Heavyweight (Long Stroke) Model

Cylinder bore size	2.7197—2.7187"
Compression ratio (1956 onwards)	7.4 to 1
Piston skirt diameter—Top	2.7180—2.7172"
Piston ring gap	.008"—.0013"
Gudgeon pin bush size	$\frac{7}{8}$ " + .0005"
	$\frac{7}{8}$ " — .00025"

Con rod diameter	high	1.7037"
	low	1.7035"
Crank pin diameter	high	1.23075"
	low	1.20350"
Crank pin rollers		
Valve spring free length		$2\frac{5}{16}$ "
Valve spring wire diameter		.168"
Drive side bearing		$1" \times 2\frac{1}{4}" \times \frac{3}{8}"$
		$1" \times 2\frac{1}{4}" \times \frac{3}{8}"$
Timing side bush diameter— <i>in situ</i>		
	high	1.1255"
	low	1.1250"
Cam wheel bushes (all)		$\frac{3}{8}" + .00075"$
		— .00075"
Finished bore size for 1964 engine		2.8352—2.834"
<b>Carburettor</b>		
Type		376/5
Bore size		$1\frac{1}{16}$ "
Main jet		220 (no air filter)
Slide		$3\frac{1}{2}$
Pilot jet		30
Needle jet		.106
Needle location		Central notch
<b>Spark Plug</b>		K.L.G. FE 80

### 350 c.c. Heavyweight (Short Stroke) Model

Cylinder bore size		2.915"—2.194"
Compression ratio		8.5 to 1
Piston skirt diameter—top		2.9163"—2.9055"
Piston Ring Gap		.008"—.013"
Gudgeon pin bush		as 350 c.c. longstroke
Con rod diameter	high	1.7037"
	low	1.7035"
Crank pin diameter	high	1.20375"
	low	1.20350"
Crank pin rollers (1962—28 rollers)		as 350 c.c. longstroke
Valve spring free length		$1\frac{17}{32}$ "
Valve spring wire diameter		$\frac{3}{16}$ "
Drive side bearings		as 350 c.c. longstroke
Cam wheel bushes		as 350 c.c. longstroke
Rocker box bushes		as 350 c.c. longstroke
<b>Carburettor</b>		as 350 c.c. longstroke

### 500 c.c. Heavyweight Model

Cylinder bore size	3.2505—3.2495"
Compression ratio	7.3 to 1
Piston skirt diameter—top	3.2475—3.2467"
Piston Ring Gap	.010"—.015"
Valve spring free length	

Valve spring wire diameter	.168"
<b>FOR OTHER DIMENSIONS REFER TO 350 c.c. LONGSTROKE</b>	
<b>Carburettor</b>	
Type	389/1
Bore size	1 $\frac{5}{8}$ "
Main jet	250 (no air filter)
Slide	3 $\frac{1}{2}$
Pilot jet	30
Needle jet	.106
Needle position	Central notch
Spark Plug	N4

#### 500 c.c. Scrambler Model

Cylinder bore size	3.2505 -3.2495"
Compression ratio	8.7 to 1
Piston skirt diameter—top	3.3795—3.7870"
Piston Ring Gap	.010—.015"
Gudgeon pin bush	see 350 details
Con rod diameter	high 2.016"
	low 2.01575"
Crank pin diameter	high 1.5156"
	low 1.5154"
Crank pin rollers	$\frac{1}{2} \times \frac{1}{4}$ " (14)
Valve spring free length	1 $\frac{17}{16}$ "
Valve spring wire diameter	$\frac{13}{16}$ "
Timing side bush diameter	high .8757"
	low .8752"
ALL other dimensions as 350 c.c. engine.—For carburettor details see 500 c.c. standard model.	

#### G85 CS Scrambler USA Model and G80 CS

Cylinder bore size	high 3.386"
	low 3.385"
Cubic capacity	30.5 cu. in. (498 c.c.)
Compression ratio	12 to 1
Carburettor $1\frac{1}{8}$ " choke	Amal 5GP2
Main jet size with air filter	290
Main jet size—without air filter	310
Throttle slide	No. 6
Air jet	.125"
Needle	5GP6 (central notch)
Ignition Timing	33° to 34° full advance
Spark Plug	Champion N57R
<b>Gear Ratios</b>	
Top	7.5 to 1
Third	9.1 to 1
Second	12.7 to 1
First	19 to 1

#### Sprocket Sizes

Rear wheel	54 teeth
Clutch	42 teeth
Final drive (gear box)	16 teeth
Engine	19 teeth

#### Chain Sizes

Front chain	$\frac{1}{2}$ " $\times$ .305" (67 links)
Rear chain	$\frac{3}{8}$ " $\times$ $\frac{1}{2}$ " (104 links)
Valve lift—inlet cam	.442"
Valve lift—exhaust cam	.339"

For all other technical details refer to the 500 c.c. regular Scrambler.  
*Note*—Lubrication system is same as 1964 regular engine.

#### 1964 to 1966 DATA

Ignition timing with full advance	
350 c.c. model	34° 8.9 mm.
500 c.c. model	38° 10.98 mm.
500 c.c. Scrambler (8.7 ratio)	38° 10.98 mm.
<b>Carburettors</b>	
350 c.c. model type	389/208
main jet size	260
Slide	3
Pilot jet	25
Needle jet	1065
Needle position	Central notch
500 c.c. model type	389/209
main jet size	290
Slide	3 $\frac{1}{2}$
Pilot jet	25
Needle jet	1065
Needle position	Central notch
<i>Note</i> —1963/64 models have 18" wheels which affects gear ratios; to remedy all heavyweight engines have one more tooth on the engine sprocket.	
The new chain sizes are:	
350 c.c. front	68 links
500 c.c. front	69 links
350 c.c. rear	98 links
500 c.c. rear	99 links

#### GEAR RATIOS

##### Scrambler Models 1957 to 1959

	First gear	Second gear	Third gear	Fourth gear (top)
Internal Ratios	2.67	1.77	1.35	1.1

Engine	Sprocket size	First gear	Second gear	Third gear	Fourth gear (top)
(A)	16 teeth	18.39 to 1	12.19 to 1	9.30 to 1	6.89 to 1
	17 "	17.30 to 1	11.47 to 1	8.74 to 1	6.48 to 1
	18 "	16.34 to 1	10.83 to 1	8.26 to 1	6.12 to 1
(B)	19 "	15.48 to 1	10.26 to 1	7.83 to 1	5.80 to 1
	20 "	14.71 to 1	9.75 to 1	7.43 to 1	5.51 to 1
	21 "	14.01 to 1	9.29 to 1	7.08 to 1	5.25 to 1
	22 "	13.37 to 1	8.86 to 1	6.76 to 1	5.01 to 1

(A) Standard for 350 c.c. Scrambler Models.  
(B) Standard for 500 c.c. Scrambler Models.

#### Trials Models

Internal Ratios	Sprocket size	First gear	Second gear	Third gear	Fourth gear (top)
		3.28	2.39	1.47	1.1
Engine		First gear	Second gear	Third gear	Fourth gear (top)
(A)	16 teeth	22.59 to 1	16.46 to 1	10.12 to 1	6.89 to 1
	17 "	standard			
	18 "	21.25 to 1	15.48 to 1	9.52 to 1	6.48 to 1
	19 "	20.07 to 1	14.62 to 1	8.99 to 1	6.12 to 1
(B)	20 "	19.02 to 1	13.86 to 1	8.52 to 1	5.80 to 1
	21 "	18.07 to 1	13.16 to 1	8.10 to 1	5.51 to 1
	22 "	17.22 to 1	12.54 to 1	7.71 to 1	5.25 to 1
		16.43 to 1	11.97 to 1	7.36 to 1	5.01 to 1

(A) Standard for 350 c.c. Trials Models.  
(B) Standard for 500 c.c. Trials Models.

#### Sprocket sizes.

Clutch	42 teeth
Gear box	16 teeth
Rear wheel	42 teeth

#### Heavyweight Models 1957-1962

Engine	Sprocket size	First gear	Second gear	Third gear	Fourth gear (top)
	17 teeth	16.6 to 1	11.05 to 1	7.91 to 1	6.48 to 1
(A)	18 "	15.65 to 1	10.39 to 1	7.46 to 1	6.12 to 1
	19 "	14.85 to 1	9.86 to 1	7.07 to 1	5.80 to 1
(C)	20 "	14.11 to 1	9.37 to 1	6.73 to 1	5.51 to 1
	21 "	13.42 to 1	8.93 to 1	6.41 to 1	5.25 to 1
(B)	22 "	12.81 to 1	8.52 to 1	6.11 to 1	5.01 to 1

(A) Standard for 350 c.c. Touring Models.  
(B) Standard for 500 c.c. Touring Models.  
(C) S/C Engine Sprocket.

#### Internal ratios.

First gear	2.67 to 1	Second gear	1.77 to 1	Third gear	1.35 to 1	Fourth gear (top)	1 to 1
------------	-----------	-------------	-----------	------------	-----------	-------------------	--------

#### Sprocket sizes.

Clutch	42 teeth
Gear box	16 teeth
Rear wheel	42 teeth

#### TABLE OF CHAINS Chain Sizes (Heavyweight Model)

Front chain	$\frac{1}{4}$ " + .305"
Rear chain	$\frac{3}{8}$ " + .380"
Magneto chain	$\frac{1}{8}$ " + .225"
Dyno chain	$\frac{3}{8}$ " + .225"

#### 1957 Models

	350 c.c. Trials	350 c.c. Scrambler	500 c.c. Scrambler
Front	67 links	66 links	68 links
Rear	98 "	97 "	98 "
Magneto	46 "	46 "	46 "
Dyno	50 "	50 "	50 "

#### 1958 Models

	350 c.c. Trials	350 c.c. Scrambler	500 c.c. Scrambler
Front	67 links	66 links	68 links
Rear	98 "	97 "	98 "
Magneto	46 "	46 "	46 "
Dyno	50 "	50 "	50 "

#### 1959 Models

	350 c.c. Trials	350 c.c. Scrambler	500 c.c. Scrambler
Front	67 links	66 links	68 links
Rear	98 "	94 "	98 "
Magneto		46 "	46 "

#### 1960-1962 Models

	350 c.c. Trials	350 c.c. Scrambler	500 c.c. Scrambler
Front	67 links	66 links	69 links
Rear	98 "	94 "	98 "
Magneto		46 "	46 "

#### ENGINE DESIGN CHANGES 250 c.c. Model

The CSR model was first introduced in 1962 starting with engine number 12128. The alterations made to the engine were;

- (1) Steel flywheel—to replace iron type.
- (2) Large diameter crank pin—to allow use of the high compression piston.
- (3) Larger inlet valve similar to the valve used on the lightweight 350 engine to improve volumetric efficiency of the engine.
- (4) Engines with number from 12828 have a modified oiling system with the stroke of the pump altered to increase oil circulation. Earlier engines cannot be modified as a new crank case is required. With this system oil was fed to the cam followers for better lubrication.
- (5) Compression ratio increased from 8 to 1 to 9.5 to 1 made possible by the introduction of steel flywheels and the large crank pin for the big end.

**Engine noises.** A light rattle audible when running without a load, and disappearing when the engine is under load, is due to slight movement in

the big end assembly. To remedy—providing the roller path on the crank pin and also the big end eye is not broken—a new set of rollers will take up the slight movement.

A similar rattle that is not affected by engine load, on engines with a number before 6850 is due to the stator in the crankcase breather being loose, this being secured by the steel tube located between the rear of the crankcase and the gear box. If the tube is broken the stator will move as the piston travels up and down, causing the rattle. The stator part number is 04220. On later engines the stator tube was discarded, the stator being now located by a bolt which will be found below the drive side bearing on the crankcase.

A rattle in the timing gear is due to wear on the cam followers, due to excessive rpm causing valve float, or weak valve springs which would have the same effect.

**Excessive oil consumption.** When the engine smokes unduly, and if the cylinder has been rebored with a non standard piston in use, this is usually due to an inefficient oil scraper ring in use. The Wellworthy DUAFLEX ring—which is the best oil scraper ring—will cure this fault. In the event of this type of ring being already in use it is possible that there is some restriction in the crankcase oil filter causing oil to accumulate in the crankcase which the oil control ring cannot cope with. To overcome this possibility a longer crankcase oil filter was introduced and first used on the 350 lightweight engines, useable for the 250 engine.

Oil can also accumulate in the crankcase if the cap for the filter 042064 is out of position blocking the oil return passage in the compartment for the filter. If there is no improvement after dealing with the points given then a rebore is necessary.

**Crankcase bearings.** Engines made in 1959 used two ball bearings in the drive side crankcase, which had short life. This was overcome by using a roller bearing in the drive side crankcase—on the outside—next to the flywheel, where the maximum load occurs. See para **Engine service** for fitting instructions.

### Heavyweight Models

#### 1947 MODELS

- (1) Improved type oil-pump plunger (two start type) with new timing side axle (identified by 2S stamped on plunger).
- (2) Oil feed passage in timing side half crankcase increased to  $\frac{9}{32}$ " diameter to prevent cavitation, with corresponding increase in diameter of the oil pipe ( $\frac{3}{8}$ " diameter).
- (3) A two piece oil pump guide pin  $\frac{1}{8}$ " in diameter to prevent wear on the pin due to the increased plunger speed.
- (4) Shorter connecting rod for centres.
- (5) The use of a long plain bush for the timing side bearings; the small roller bearing is now obsolete. Engines fitted with the old type bearing can use a modified bush with two external diameters. The steel sleeve is retained to locate the new bush on the large external diameter.

#### 1948 MODELS

- (1) Annular groove in pump plunger increased from  $\frac{3}{16}$ " to  $\frac{1}{4}$ " diameter

with suitable guide pin.

- (2) Wire-wound pistons fitted to 500 c.c. models.
  - (3) 500 c.c. type high crankcase used for 350 c.c. models after engine number 8000.
  - (4) 500 c.c. flywheels used for the 350 c.c. model.
- In addition to these engine design changes;
- (5) Larger brakes (7" diameter) were fitted.

#### 1949 MODELS

- (1) New type cylinder head with hair-pin valve springs with rocker box to suit.
- (2) Valve lifter transferred from crankcase to rocker box.
- (3) Wire-wound pistons for all models.
- (4) Longer valves, hardened valve end caps discarded.
- (5) New rockers for longer valves, also new valve guides.

#### 1950 MODELS

- (1) Alloy cylinder heads and barrels used on Competition models only. Steel crankpin washer in place of bronze type.

#### 1951 MODELS

- (1) Alloy cylinder head used on both touring type engines. Crankpin washers discarded, flywheels altered.

#### 1952 MODELS

- (1) Open tray valve spring seat, prongs for valve springs increased in length.
- (2) Cylinder barrel lengthened  $\frac{1}{8}$ " on 500 c.c. touring engine, compression plate discarded.
- (3) Recess for driving side bearings in crankcase with two diameters, for close and easy interference fit to avoid "end loading" of these bearings.
- (4) Top compression ring chrome plated.

#### 1953 MODELS

No change.

#### 1954 MODELS

- (1) Oil feed in rocker box modified to increase oil supply to rocker end of inlet valve and stop valve spring wear.
- (2) New rockers for valve ends with groove in side for oil duct.
- (3) High-lift cams.
- (4) Larger diameter timing side shaft, with flywheel to suit.
- (5) Two diameter timing side bush, steel sleeve discarded.
- (6) Automatic ignition control on 500 c.c. model.

#### 1955 MODELS

- (1) New crankcase to use one small and one large driving side bearing.
- (2) New driving side flywheel (keyways at 180°).
- (3) Circlip fitted to exhaust valve guide.

#### 1956 MODELS

- (1) Cylinder wall oil feed discontinued.
- (2) Compression ratio increased to 7.5 for 350 c.c. models, 7.3 for 500 c.c. models.
- (3) Oil tank felt filter deleted and magnetic filter fitted in crankcase.



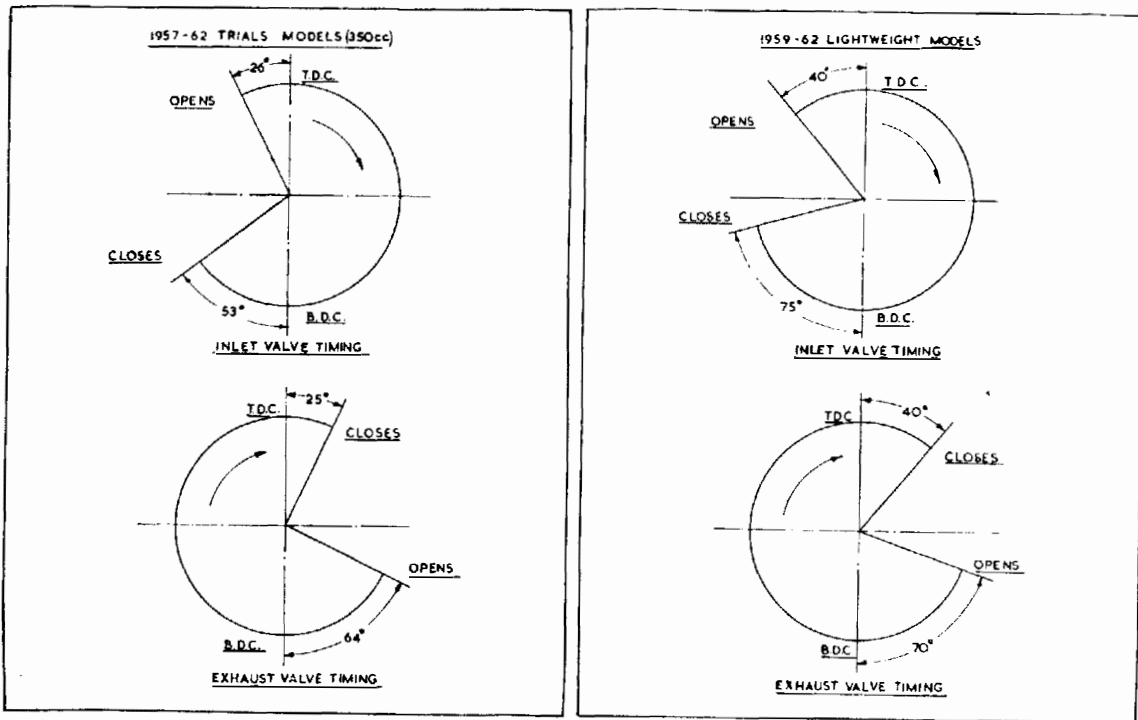

FIG 1

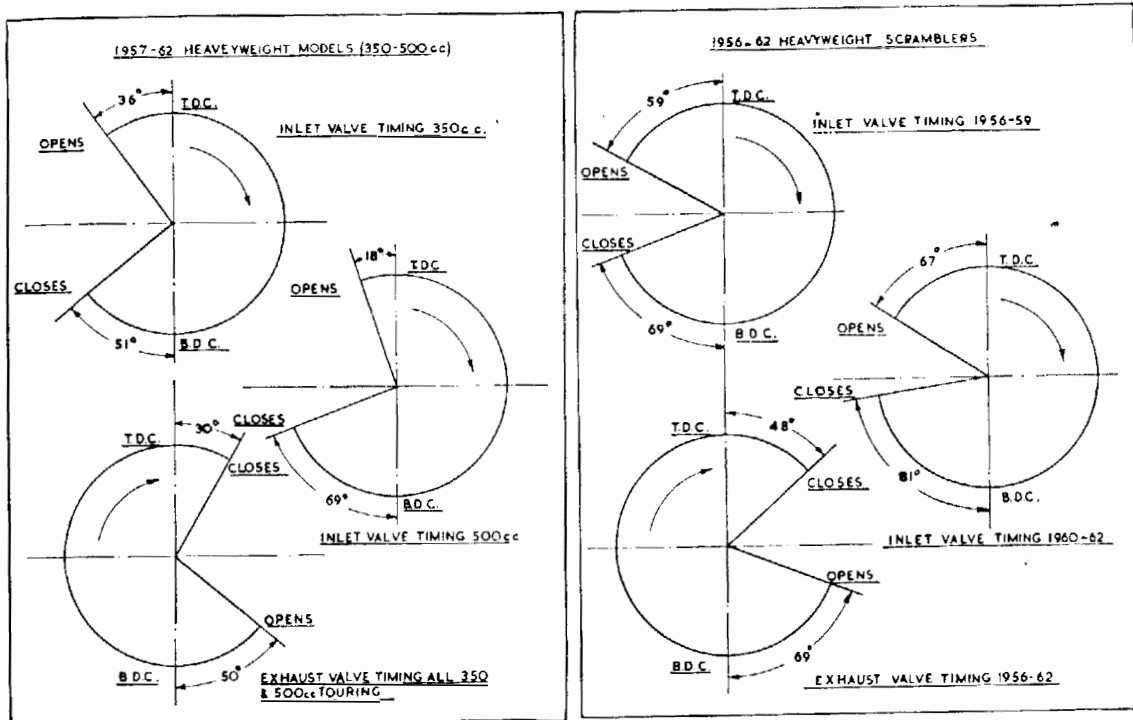

FIG 2

## LUBRICATION

### Lightweight Models

This is by true dry sump system. The oil tank, or reservoir, is integral with the crankcase. The oil pump has only one moving part, i.e., the oil pump plunger, which rotates and reciprocates. Rotation is created by the worm gear on the timing side flywheel axle.

Reciprocation is caused by engagement of the oil pump guide pin with the profiled groove in the oil pump plunger. The oil pump is designed so that the sump scavenging capacity is greater than the delivery, thus keeping the crankcase sump free of oil during normal running conditions.

Whilst the oil reservoir is integral with the crankcase, oil is fed to the pump by gravity, on the same principle as a machine fitted with a separate oil tank, but without the use of external oil pipes.

**Engine oil pump.** If, for any reason, the crankcase is dismantled *the oil pump plunger must be removed from its housing before attempting to separate the crankcase halves.* It is also necessary to remove the small timing pinion.

**Important.** *Under no circumstances must either the pump plunger or guide screw be disturbed in ordinary routine maintenance.*

**Engine oil circulation.** Provision is made to observe the oil circulating, which is visible after removing the oil filler cap on the right side of the crankcase.

The oil pump forces oil through:—

- Passages drilled through the timing side flywheel axle, timing side flywheel and crank pin to lubricate the timing side bearing and the big-end bearing. The splash passes to interior of cylinder, to lubricate the cylinder and piston, and then falls into the crankcase sump.
- From the front oil pump housing to the rocker box via passages in the cylinder barrel, lubricating the rocker gear and valve stems. Oil from the rocker gear drains by gravity via the push rod tunnels to the timing gear case at a pre-determined level. The over-spill drains into the crankcase sump.
- The oil pump extracts oil from the crankcase sump, metal impurities are collected by a magnetic filter incorporated in the sump drain plug. The oil is again filtered by a fabric filter located in the crankcase, (see Fig. 3) before returning to the oil tank reservoir.

For valve guide lubrication see paragraph "Adjustment of oil feed".

**The oil reservoir.** The normal oil level is 1 inch below the filler cap orifice, the oil content is 2½ pints. Run the engine for a short period to scavenge the sump, before "topping up".

After the first 500 miles (800 kilometres) again at 1,000 miles (1,600 kilometres) and subsequently at 5,000 mile intervals (8,000 kilometres) the oil reservoir should be drained the oil filter cleaned in petrol and the reservoir replenished with new oil. It is preferable to drain the oil after a run and when the oil is warm. A drain plug is fitted to both the crankcase sump also the oil reservoir. The drain plug for the reservoir is close to the bottom front crankcase bolt.

**The crankcase fabric filter.** The filter is cylindrical in shape and made

from a close grained felt, supported by a wire cage, the cage is not detachable. The filter is mounted in the front of the drive side crankcase and is retained by a cap washer, spring and plated dome nut. At the far end of the filter, a steel cup is fitted to support the filter and seal the filter end, so that all returned oil will pass through the filter.

**To remove the fabric filter.** Using the Allen Key 018667 supplied in the tool kit, unscrew the domed nut and take out the spring. If the ends of a pair of round nosed pliers are opened outwards (to grip the inside of the cup washer) the washer and filter can be extracted from the crankcase.

It may so happen that the washer only will come out, if so, the filter can also be extracted in a similar manner. It is also possible that the steel cap washer, at the far end of the filter, will remain in the crankcase, if so this is of no consequence. The filter should be handled with care and if damaged it should be discarded and replaced by a new one.

To clean the filter it should be immersed in petrol and when thoroughly clean it should then be allowed to dry before re-insertion.

**To remove magnetic filter.** Incorporated with the crankcase sump plug is a powerful magnet, which does not require frequent attention. For cleaning place a tray under the crankcase, unscrew the sump plug, with the use of a good fitting ring spanner.

Metal particles adhering to the magnet can be removed by wiping with a grease coated rag, the grease will collect metal particles on the rag. Keep the magnet away from large pieces of steel or iron, as contact can impair the efficiency of the magnet.

**Adjustment of oil feed.** The internal flow of oil is controlled by fixed restrictions, with the exception of the oil feed to the inlet valve guide, which is regulated by a needle pointed screw located in the cylinder head (see Fig. 4) and secured by a locknut.

To adjust the oil feed loosen the lock nut and screw home lightly the regulating screw, then unscrew it the smallest amount possible and re-tighten the lock nut.

An excess of oil to the inlet valve guide will cause a smoky exhaust and heavy oil consumption. Insufficient oil can cause the valve to run dry with a squeaking noise.

**Exhaust valve stem lubrication** (before 1964). From a drilling in the exhaust rocker axle boss in the rocker box, oil is fed to a cavity in the cylinder head. A further drilling from this cavity, through the cylinder head to an oil hole in the valve guide, provides positive lubrication for this part of the engine and needs no adjustment.

**Crankcase release valve.** Crankcase pressure is released into the atmosphere through a timed and ported release valve. The ported portion for this valve is situated between the two driving side bearings, the valve outlet is adjacent to the gear box housing. The valve cannot become deranged and needs no attention.

**Gear box lubrication.** To top up or replenish oil for the gear box remove the inspection plate secured by two screws on the gear box end cover.

Use one of the grades of oil specified, on no account must grease be used.

The normal oil content is 3 pints (1.8 litres), the gear box must not be completely filled with oil. After draining and replenishing the oil at the first 500 miles (800 kilometres) top up every subsequent 1,000 miles (1600 kilometres) to a level just below the bottom of the orifice for the inspection plate.

**Front chain lubrication.** The front chain is lubricated with engine oil filled to the front chain case, which forms an oil bath. If the lower of the two slotted screwed caps on the chain case is removed, the oil level can be observed. The correct oil level is just above the bottom run of the primary chain. To top up, remove both slotted screwed caps and fill oil through the uppermost aperture, checking the level through the lower. A drain plug is situated immediately below the clutch assembly. If the chaincase is drained, refill with 1 pint (.6 litres) of engine oil.

**Rear chain lubrication** (exposed chain). The rear chain should be removed occasionally, particularly during wintry or prolonged inclement weather, for lubrication. The life of this chain will be prolonged if it is lubricated effectively and not allowed to run in a dry condition.

With the chain removed, scrub the side plates with a wire brush then wash in paraffin (Kerosene). Use a small quantity of one of the recommended greases in a flat tin and heat until the grease is fluid. Immerse the chain and re-heat the grease, which will cool off. Soak for ten minutes, take out the chain, wipe off surplus grease and refit.

**Caution:** When refitting the chain connecting link, the closed end of the spring clip must face the way the chain travels.

**Wheel hub lubrication.** Both hubs are pre-packed with grease during assembly, which prevents the entry of water as well as lubricating the bearings. After the first 5,000 miles (8000 kilometres) and before 10,000 miles (16000 kilometres) dismantle and clean the hub bearings and repack with fresh grease.

**Speedometer lubrication.** A grease nipple is fitted to the speedometer gear box which is attached to the right side of the rear wheel. Use grease sparingly, no other part of this equipment requires lubrication.

**Rear fork hinge (swinging arm).** Apply grease gun on nipple mounted on the right side of the fork hinge, during routine maintenance (use S.A.E. 140 oil).

**Rear brake pedal.** A grease nipple is fitted underneath the pivot part of the pedal.

**General.** Occasionally apply a little engine oil to parts such as control levers, and cables, brake rods, stands, etc. Use a little grease to lubricate the twist grip rotor.

### RECOMMENDED LUBRICANTS

Efficient lubrication is of vital importance and it is false economy to use cheap grades of oil. When buying oils or grease it is advisable to specify the brand as well as the grade and, as an additional precaution, to buy from sealed containers.

#### ENGINE

Ambient temperature above 50°F. (10°C.) use S.A.E. 20/50 or straight S.A.E. 50.

Ambient temperature above 32°F. (0°C.) use S.A.E. 20/50 or straight S.A.E. 30.  
Ambient temperature below 32°F. (0°C.) use S.A.E. 10/30 or straight S.A.E. 20.

The following brands are recommended:

Mobiloil  
Castrol  
Energol  
Essolube  
Shell  
Regent Advanced Havoline

#### GEARBOX

Ambient temperature above 32°F. (0°C.) S.A.E. 50 or EP90.  
Ambient temperature below 32°F. (0°C.) S.A.E. 30

#### WHEEL HUB AND FRAME PARTS

Mobilgrease MP  
Castrollease LM  
Energrease C3  
Regent Marfax Multipurpose  
Shell Retinax A or C.D.

#### ESSO Multipurpose

#### TELEDRALIC FRONT FORKS

Mobiloil Arctic (S.A.E. 20)  
Energol (S.A.E. 20)  
Shell X-100 Motor Oil 20/20W (S.A.E. 20)  
Castrolite (S.A.E. 10W-30)  
Essolube 20 (S.A.E. 20)  
Regent S.A.E. 20 use S.A.E. 30 for G2 and G2CS

#### REAR CHAINS

Mobilgrease MP  
Energrease A.O.  
Regent Marfax Multipurpose  
Esso Fluid Grease  
Castrollease  
Grease Graphited  
Shell Retinax A or C.D.

### PERIODICAL MAINTENANCE

#### 250 c.c. and 350 c.c. Lightweight Models 350 c.c. and 500 c.c. Heavyweight Models

Regular maintenance attention to lubrication and certain adjustments must be made to ensure unfailing reliability and satisfactory service. This necessary attention is detailed below and owners are strongly recommended to follow carefully these suggestions and to make a regular practice of doing so from the first.

#### DAILY

**Oil tank/Reservoir** Inspect oil level and top-up if necessary.  
Check oil circulation.  
**Petrol tank** Check level and re-fill if necessary

	<b>WEEKLY</b>
<b>Oil tank</b>	Check level and top-up if necessary.
<b>Tyres</b>	Check pressures and inflate if necessary.
	<b>EVERY 500 MILES</b>
<b>Oil tank/Reservoir</b>	Drain at first 500 miles, re-fill with new oil and clean filter.
<b>Ignition</b>	Check contact breaker points.
<b>Gear box</b>	Drain at first 500 miles and re-fill.
<b>Chaincase</b>	Check level of oil when machine is standing vertically on level ground. Fill up if level is low. (See chain lubrication.)
<b>Battery</b>	Inspect each cell for level of electrolyte and top up with distilled water if necessary. Level of electrolyte should be just over top of plates. Beware of overfilling.
	<b>EVERY 1,000 MILES</b>
<b>Oil tank/Reservoir</b>	Drain at first 1,000 miles and re-fill with new oil.
<b>Rear chain</b>	In wet weather remove and soak in molten grease.
<b>Gear box</b>	Check oil level.
<b>Hubs</b>	Inject small amount of grease where provision
<b>Expanders</b>	Inject small amount of grease is made
<b>Steering head</b>	Inject small amount of grease )
<b>Small parts</b>	Smear all moving parts with engine oil and wipe off surplus.
<b>Chaincase</b>	Drain, and re-fill, or monthly.
	<b>EVERY 2,000 to 5,000 MILES</b>
	(according to road conditions)
<b>Air filter</b>	(If fitted) clean and re-oil filter element.
	<b>EVERY 3,000 MILES</b>
<b>Oil Reservoir</b>	(Lightweight models) drain and re-fill with new oil. If machine is used for short journeys, renew oil every 3 months.
<b>Filter</b>	(Lightweight models) clean filter in crankcase.
<b>Rear chain</b>	In dry weather remove and soak in molten grease.
<b>Brake pedal</b>	Inject small amount of grease.
<b>Speedometer</b>	Inject small amount of grease into speedometer gear box, if fitted with grease nipple.
<b>Ignition</b>	Clean contact breaker points and re-set if necessary.
<b>Plug</b>	Clean sparking plug and re-set points as necessary.
<b>Steering head</b>	Test steering head for up and down movement and adjust if necessary.
<b>Bolts and nuts</b>	Check all nuts and bolts for tightness and tighten if necessary but beware of over-tightening.
<b>Rockers</b>	Check OHV rocker adjustment and correct if necessary.
	<b>EVERY 5,000 MILES</b>
<b>Oil tank</b>	(Heavyweight models) drain and re-fill with new oil. If machine is only used for short runs renew oil every three months instead of mileage interval.

<b>Filters</b>	(Heavyweight models) clean metal mesh filter in oil tank.
<b>Ignition</b>	Clean and adjust as detailed in Electrical section.
<b>Dynamo</b>	Clean as detailed in Electrical section.
<b>Front fork</b>	Check each side of front fork for hydraulic fluid content and, if necessary, top up. Insufficient oil content is indicated by abnormally lively action.
<b>Carburetter</b>	Remove carburetter float chamber side cover and clean interior. Also detach petrol pipe banjo and clean gauze strainer.
	<b>EVERY 10,000 MILES</b>
<b>Magneto &amp; Dynamo</b>	Get a Lucas Service Station to dismantle, clean, lubricate and generally service.
<b>Air filter</b>	(If fitted) renew filter element.

### ENGINE SERVICING—ALL MODELS

**Tappet adjustment.** The top ends of the two long push rods have screwed extensions. These are locked in position by nuts, thereby providing tappet adjustment. The correct tappet clearances, with valves closed and engine warm (not hot) is *nil*. This means the push rods should be free enough to revolve and, at the same time, there should be no appreciable up and down play. See fig. 3a on p. 25.

#### Prepare to adjust tappets by:

Set piston to T.D.C. (both valves closed).

Remove the three nuts, and fibre washers under them, retaining tappet cover to rocker box.

Take away cover.

#### Adjust tappets by:

With spanners, hold the sleeve, either valve and slacken lock nut. Then screw, in or out, the head until the clearance is *nil*. Tighten lock nut and re-check the clearance.

#### Finally

Check adjustment so that, with no up and down movement, the long push rods are free to revolve when the valves are closed.

#### Complete adjustment by:

Replace rocker tappet cover taking care to replace fibre washer that is under each retaining nut.

As mentioned elsewhere do not over-tighten the nuts because the joint is made with a rubber fillet and undue pressure is not necessary.

**NOTE**—In normal conditions tappet adjustment should not be necessary more frequently than about every five thousand miles or after decarbonising and grinding valves. If adjustment is found necessary more frequently the cause should be investigated at once.

For service work on the upper part of the engine, with the exception of tappet adjustment, the twin seat and petrol tank should be removed for accessibility.

**To remove the rocker box.** Remove the three nuts and fibre washers securing the rocker box cover, also the sparking plug.

Fig 3 Exploded view of 250 c.c. and 350 c.c. OHV engine

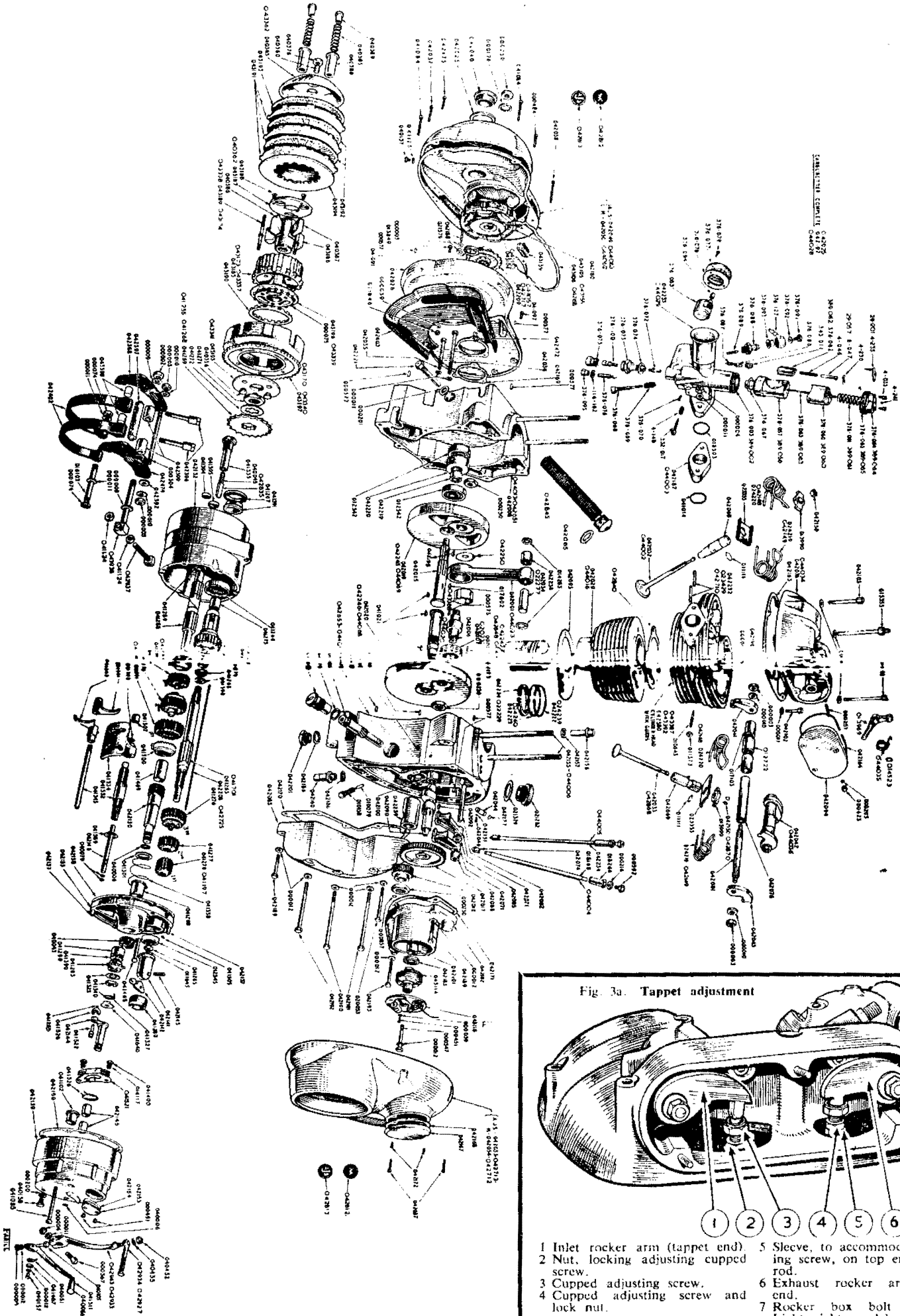
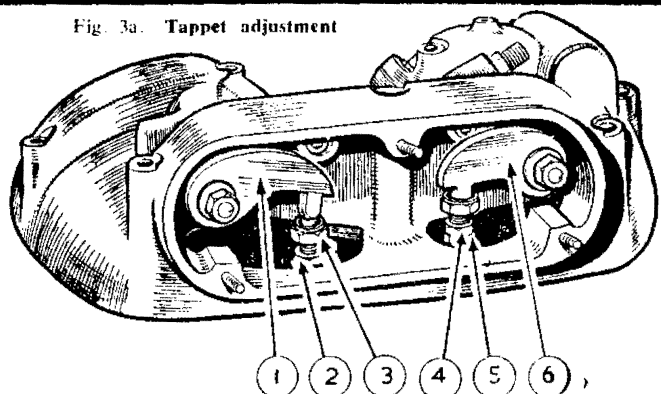

Fig 3a. Tappet adjustment



- 1 Inlet rocker arm (tappet end)
- 2 Nut, locking adjusting cupped screw.
- 3 Cupped adjusting screw.
- 4 Cupped adjusting screw and lock nut.
- 5 Sleeve, to accommodate adjusting screw, on top end of push rod.
- 6 Exhaust rocker arm (tappet end).
- 7 Rocker box bolt (used on Lightweight models only).

Turn the engine until both valves are closed, i.e. after the inlet valve has opened and just closed.

Remove two nuts and the bolt securing the engine steady bracket to the rocker box and frame. Disconnect valve lifter cable.

Take out the nine bolts securing the rocker box to the cylinder head (one of these bolts is inside the rocker box). The location of these bolts must be noted as they are dissimilar.

Tilt upwards the right side of the rocker box, extract both push rods and identify their location for replacement in their original positions, remove the rocker box from the cylinder head.

**To remove the cylinder head.** Remove the exhaust pipe and silencer as one unit, then the accessory compartment cover and air filter tube if fitted. Do not rock the exhaust pipe sideways unduly to extract it from the exhaust port which can cause the end of the pipe to close in and result in gas leakage, with movement between the pipe and the port when the engine is hot. Instead squirt a little paraffin or petrol into the port and try again.

Unscrew the cap on the carburettor mixing chamber, take out both slides, wrap them in a piece of rag and attach it to the frame, out of harm's way. Unscrew the petrol pipe union and take away the petrol pipe. Four sleeve nuts and one bolt retain the cylinder head to the barrel, with these removed, the cylinder head with carburettor attached to it can be separated from the cylinder.

**NOTE**—Four nuts only are used on heavyweight engines.

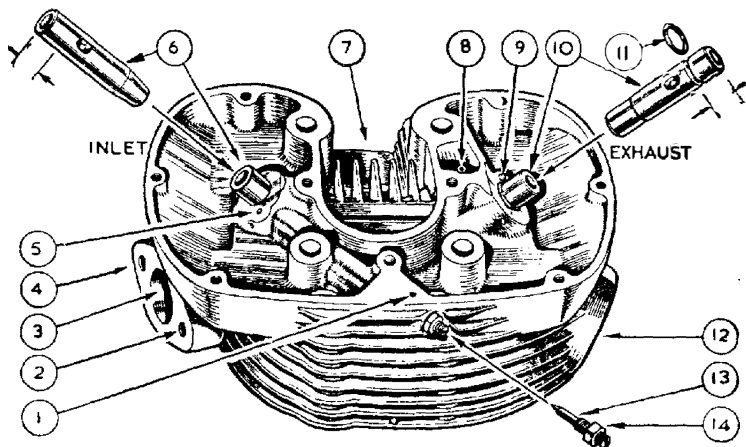

FIG 4 Cylinder head

**Decarbonisation.** Instead of the usual stipulated mileage interval between periods of decarbonisation, it is recommended that this is undertaken only when the need becomes apparent because of loss in power, heavy petrol consumption or generally reduced performance.

When undertaken, unless it is thought necessary to inspect the piston and rings, the cylinder barrel is best left undisturbed.

Before starting this work have available a gasket set, and if the machine has covered considerable mileage, a new set of piston rings also.

Carbon formed on the piston crown and in the sphere of the cylinder head, can be scraped off with a cheap steel rule, with the sharp corners removed, or similar tool. Deal with the cylinder head before removing the valves, and do not use emery cloth or other abrasives for this work.

**To remove and replace the valves and guides.** The hair pin valve springs are removed by inserting the index finger through the coil of the spring and pulling upwards sharply.

A light tap on the valve spring collar will expose the valve split collets (which should be put in a place of safety), then take out the valve.

Both valve guides are located by an external circlip. The cylinder head must be gently and uniformly heated before attempting to remove or replace the guides.

With the head pre-heated tap the guide upwards out of the port sufficiently to enable the circlip to be prised out of its groove. Reheat the head and drive out the guides through the cylinder head. When refitting the guides, pre-heat the head and verify that the oil holes are in alignment with holes in the cylinder head. Use a valve spring compressor where coil springs are used.

**Valve grinding.** The grinding is accomplished by smearing a thin layer of fine grinding paste (obtainable ready for use at any garage) on the valve face and then, after inserting the valve in the head, partially revolve, forwards and backwards, while applying light finger pressure to the head, raising the valve off its seat and turning to another position after every few movements. (Never revolve the valve continuously in one direction).

When the abrasive ceases to bite, remove the valve and examine its face. The grinding may be considered to be satisfactorily completed when a continuous matt ring is observed on both valve face and seat.

After grinding, all traces of abrasive must be carefully washed off with petrol and a piece of rag, moistened in petrol, should be pulled through the bore of each valve guide to remove any abrasive that may have entered. A holder for the valve, when grinding in the valve, can be supplied. The part number is 017482.

**Replacing the valves.** A valve spring compressor is required to compress the springs and a special tool which is inexpensive, can be obtained from dealers. Before fitting the valve springs, position correctly the valve spring seat. The raised portion on the underside is located with the depression (5) in cylinder head. (Fig. 4.) The inlet valve is the larger of the two valves and it is vitally important to locate correctly the two split collets into the grooves on each valve stem.

Clean the valve guide bores with a piece of clean rag, apply a little

oil on the valve stems and also inside each guide before assembly.

**Removing the cylinder and piston.** With the cylinder head removed, the barrel can be raised vertically to clear the holding down studs. Before doing so, position the engine with the piston on the top of its stroke. Have available a piece of clean rag. Raise the cylinder sufficiently to enable the rag to be put into the throat of the crankcase (under the piston) as a precaution against a broken ring falling into the crankcase, then lift the cylinder clear of the four studs passing through it. Make a mark inside the piston to indicate front.

The gudgeon pin is a sliding fit in both the piston and connecting rod. Use round nose pliers to compress and extract the circlip (it is immaterial which one is removed) then push out the gudgeon pin and lift the piston off the connecting rod.

Do not disturb the piston rings unless absolutely necessary.

If new piston rings are used, they are ready for fitting, as the ring gap is allowed for during manufacture.

The top compression ring is chromium plated and has a slightly tapered extension. When new, the word TOP is etched on the ring face to indicate which way it should be fitted. Fit first the scraper or oil control ring, then the two compression rings, to avoid breakage do not expand these rings unnecessarily.

**Refitting the piston.** Before refitting the piston apply a little oil to the gudgeon pin, also to the bosses for the gudgeon pin in the piston. Place the piston over the connecting rod in the same way as it was removed, or in accordance with the marking made, and then introduce the gudgeon pin through the piston, connecting rod and piston bosses.

It is vitally important to correctly locate the gudgeon pin circlip, and a little extra care and time should be devoted to this most simple and important operation. Use round-nosed pliers to introduce the circlip into its groove, using a rotary motion then verify that the circlip is correctly located.

**Refitting the cylinder barrel.** Fit a new cylinder base gasket, after removing broken pieces of the old one. Use a little jointing compound on the base of the cylinder and stick a new gasket to it, no jointing compound should be on the crankcase face. Set the piston ring gaps at 120°. Pass the cylinder over the four long studs and lower it gently at the same time compressing each piston ring in turn with the fingers, until the cylinder has passed the scraper ring when it can be lowered on to the crankcase.

**NOTE**—Some clean rag under the piston to fill the throat of the crankcase will safeguard against a broken piston ring falling into the crankcase.

**Refitting the cylinder head.** The cylinder head gasket also acts as an oil seal for the push rod tunnels, consequently it must be in good order if it is to be used again. To avoid the possibility of subsequent attention a new gasket is desirable.

This gasket is neither symmetrical nor reversible and it must be placed on the cylinder in the correct way.

A study of the cylinder barrel face will show an elongated hole (where the push rods operate).

Just behind is a tapped hole for the cylinder head bolt. (Lightweight engines only.) Close to the cylinder bore and to the right of the cylinder head bolt hole is a smaller hole, which is the oil feed passage from the pump to the rocker gear.

Place the gasket on the cylinder so that the oil feed hole in the cylinder registers with the small hole in the gasket.

Put the cylinder head in position, refit the four cylinder head sleeve nuts and the long cylinder head bolt. Do not omit the five washers. First tighten the four sleeve nuts diagonally—not one side at a time—then tighten the long bolt, until all are firmly tightened. If a torque spanner is available it should be set to 35 foot lbs. for the four sleeve nuts only.

**Refitting the rocker box.** Before attempting to refit, make sure the piston is on T.D.C. of the firing stroke, with both cam followers down.

Use a new rocker box gasket for this assembly. In the centre portion of this gasket is a projection with a small hole in it. There is also a similar size hole in the cylinder head which is the oil feed passage from the oil pump through the cylinder to the rocker gear. It will be readily seen that if the rocker box gasket is reversed the oil feed passage will be sealed, therefore ensure that the gasket is properly located before fitting the rocker box. With the rocker box gasket correctly located, take up the rocker box, pass all the holding down bolts through it, put the rocker box into position.

Take up the two engine push rods, tilt the right side of the rocker box upwards, then introduce the push rods through the head and cylinder. The exhaust push rod operates with the cam follower nearest to the contact breaker. (See Fig. 3.)

Locate the rocker arms in the push rod adjusters and first tighten the two central rocker box bolts which have screwed extensions.

Tighten the remainder diagonally including the one inside the rocker box.

Washers are fitted under the heads of all these bolts.

It should be remembered that a soft gasket is used between the cylinder head and the rocker box, therefore the degree of tightness of these bolts is a matter of good judgment and commonsense.

Re-adjust the tappets as previously described.

## IGNITION TIMING Lightweight Models

Before setting or checking the ignition timing, make sure the contact breaker gap at full separation, is .012". (See details on Contact Breaker.)

Reference to Fig. 5 will indicate the principle used.

**To check the timing.** Position the engine as detailed for tappet adjustment. Remove the sparking plug, the cover for the contact breaker and engage top gear. Obtain a short length of stiff wire or wheel spoke about 5" long. Insert the wire through the sparking plug hole, until it touches the piston crown. By slowly moving the rear wheel backwards and forwards the top dead centre of the piston travel can be ascertained. Keep the wire vertical as far as the plug hole will permit—make a mark

on the wire to register with the seating for the sparking plug on the cylinder head. Take out the wire and make a further mark on it  $\frac{1}{4}$ " ABOVE the previous mark.

Put the wire through the sparking plug hole, then turn the engine BACKWARDS until the top mark on the wire registers with the seating for the sparking plug, the piston is now  $\frac{1}{4}$ " before top dead centre. A  $\frac{3}{8}$ " hole is drilled in the contact breaker base plate to enable a small screwdriver to be inserted, and engaged between the two bob weights for the automatic ignition control. (See Fig. 5.)

Turning the screwdriver clockwise will separate the bob weights to the fully advanced position. If the timing is correct the contact breaker points should be just about to separate.

The exact point of separation can best be found by inserting a piece of cigarette paper between the points, which when pulled lightly will be free when the contact breaker points separate.

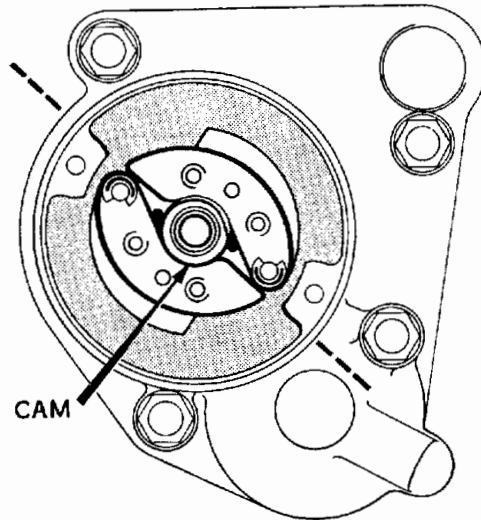

FIG 5 Automatic ignition advance mechanism  
(approximate ignition setting)

**To adjust ignition timing.** By slackening the two screws in the slotted holes on the contact breaker base plate, the plate can be moved either clockwise or anti-clockwise to adjust the timing as required.

Move the plate clockwise to advance and use the method described for checking to obtain the correct timing.

**To reset ignition timing.** As the ignition advance is limited to  $\frac{1}{4}$ " B.T.D.C., this setting is critical and must be carefully carried out. The automatic ignition control unit is a taper fit on the camshaft, retained by a central bolt. To remove this unit take out the retaining bolt, use in its place a withdrawal bolt, Part No. 042247. Screw home this bolt—do not use undue force—then tap the head of the bolt lightly which will separate the unit from the shaft.

**NOTE**—The contact breaker cam is detachable and if it is inadvertently removed, the timing should be rechecked after refitting the cam, before attempting to start the engine.

### VALVE TIMING Lightweight, Including Scrambler Models

The cam wheel, also the small timing pinion which drives it, are both marked to facilitate assembly.

If for any reason, the cam wheel is removed, to re-assemble rotate the engine until the piston is on T.D.C. of the stroke, the mark on the small timing pinion tooth will then be at 11 o'clock. Take up the cam wheel, raise both cam followers, then introduce the cam into the crankcase with the mark on the tooth gap to register with the mark on the small pinion.

These markings have been selected to give the most effective valve timing and best engine performance.

To check the valve timing, as a single piece camshaft is used, it is only necessary to record the inlet valve opening also the exhaust valve closing positions to verify that the valve timing is correct.

The average valve timing, taken with .010" rocker clearance is:—

Inlet valve opens 40° B.T.D.C.

Exhaust valve closes 40° A.T.D.C.

See TAPPET ADJUSTMENT for running pushrod clearance.

### IGNITION TIMING—COIL IGNITION Heavyweight Models

To understand the principle, a study of illustrations should be made. The automatic timing control is a taper fit on the shaft for the inlet cam, retained by a central bolt. The cam separating the contact breaker points is rotated by two pegs engaged in the plates for the unit springs. As the cam is detachable, the position of the cam should be noted, before it is removed. Before setting the ignition timing it is essential to check the contact breaker gap.

**Checking contact breaker gap.** Remove two screws securing the cover mounted on the timing case, also the cover. Rotate engine to fully separate contact points.

Check gap which should be .014—.016".

To adjust the gap release slightly the two inner screws securing the fixed contact plate and adjust the gap as required by moving the pivot plate in the required direction.

**Removing the automatic timing control.** After taking off the cover:

Remove the two screws passing through the slotted holes in the fixed contact breaker plate and remove the plate.



Remove the bolt securing the automatic timing control to the cam wheel shaft. Fit a 024328 withdrawal bolt in place of the fixing bolt removed which should be lightly tightened. A sharp blow on the end of the withdrawal bolt will dislodge the unit from the shaft.

Do not disturb the contact breaker cam.

**Setting the ignition timing.** Maximum advance 500 c.c. also 350 c.c. with engine number before 41575 is  $\frac{1}{2}$ " or 39 deg. (12.7 mm). 350 c.c. after 41575.  $\frac{11}{32}$ " or 34 deg. (8.73 mm). With the A.T.C. retarded use  $\frac{1}{4}$ " for  $\frac{1}{2}$ " or  $\frac{3}{16}$ " in place of  $\frac{11}{32}$ ".

To set the timing, have available a stiff wheel spoke or similar object  $5\frac{1}{2}$ " long.

Remove H.T. cable and sparking plug.

Remove automatic timing control as already described.

Remove the rocker box side cover.

Turn engine so that both valves are closed (inlet valve opens then closes) then engage top gear.

Insert timing rod through sparking plug hole, feel piston by rocking engine forwards or backwards by turning the rear wheel until it can be felt that the piston is at the extreme top of its stroke with both valves closed.

Refer to Fig. 6, and fit automatic advance control, with the gap formed by the two bob weights in line with the two tapped holes, used to secure contact breaker plate. It should be noted that the peak of the cam, or narrowest part, when correctly positioned is approximately at 12 o'clock.

Press the unit firmly on to the shaft that drives it and give the end a sharp tap before re-fitting the fixing bolt. Insert a wood wedge between bob weights to fully separate if fully advanced method is used.

Take up the timing rod, check piston position in case the engine has moved. Hold the timing rod as vertically as possible through the sparking plug hole, verify piston is at the top of the stroke. Make a mark on the timing rod flush with the top face of the sparking plug hole, then withdraw the rod.

If the fully advanced method is used make a further mark on the timing rod exactly  $\frac{1}{2}$ " ABOVE the previous mark.

With the A.T.C. retarded make the second mark as shown in the figures given.

Put the timing rod back through the sparking plug hole and by moving the rear wheel turn the engine BACKWARDS until the highest of the two marks on the timing rod is flush with the top face of the sparking plug hole, dependant on the timing method used.

Fit the contact breaker plate with the capacitor at 3 o'clock, lightly tighten the fixing screws. The exact position of contact point separation is best determined by inserting a strip of cigarette paper between the contact points and moving the plate in a clockwise direction until the paper can be pulled away freely.

If a wedge is used to fully advance the unit, scribe a pencil line on the contact breaker plate and a similar line on the plate housing, both lines in register. Remove the contact breaker plate, take away the wedge and

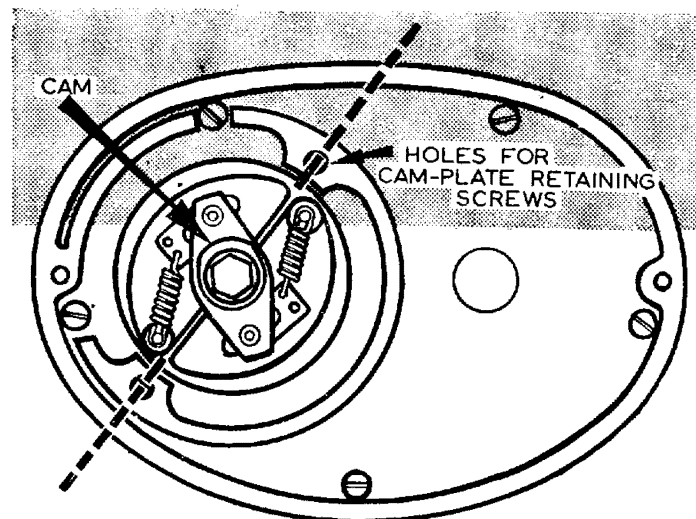

FIG 6 Setting the ignition timing (Heavyweight)

re-fit the plate with the two scribed lines in register, and firmly tighten the fixing screws.

As the ignition timing is important, a re-check should be made, before re-fitting the sparking plug, rocker cover, etc.

### MAGNETO IGNITION

**To re-time the ignition.** The normal advance is 39° ( $\frac{1}{2}$ ").

Have available a stout screwdriver, or an old type tyre lever with turned up end, also a small rod or stout wheel spoke  $5\frac{1}{2}$ " long

Before setting the ignition firing point it is essential the magneto contact breaker points are correctly adjusted. Therefore always check these first.

Check contact breaker points by:—

Expose contact breaker by removing moulded end cover of magneto (secured by 3 captive screws).

Check setting of contact breaker points and, if necessary, re-set same.

Set ignition firing point by

Remove:—

The sparking plug high tension cable from plug  
The sparking plug.

The magneto chain case cover.

The rocker box side cover.

Unscrew, several turns, nut retaining magneto sprocket to camshaft.

(No need to remove nut.)

Lever off sprocket until it is loose on the taper of the shaft. (Use stout screw-driver or old type tyre lever.)

Turn over engine till both valves are closed.

Insert rod through sparking plug hole, feel piston by rocking engine forwards or backwards till it is felt the piston is at the top of its stroke with both valves closed.

Mark rod flush with top face of sparking plug hole. Remove rod and measure  $\frac{1}{2}$ " above the flush mark and record position on rod.

Turn the front plate of the automatic unit with the fingers and thumb to its limit of movement and insert a wood wedge to hold the control in the fully advanced position.

Replace rod in sparking plug hole.

Slightly rotate engine BACKWARDS until upper mark on rod is flush with top face of sparking plug hole. (To rotate engine, engage top gear and turn back wheel by hand.) Rotate sprocket on magneto armature shaft, in anti-clockwise direction (as seen from sprocket end of magneto), till the contact breaker points are just about to separate. (To find the exact moment for the commencement of the point separation, place a piece of tissue paper between the points and turn the armature shaft (by the sprocket on it) until the paper is just released, and no more, by a gentle pull.)

Tighten nut on camshaft and ensure engine, and/or magneto shaft, does not move in doing so.

Re-check the setting which must be  $\frac{1}{2}$ " before top dead centre. (With the ignition fully advanced.)

Do not omit to remove the wood wedge securing the automatic unit in the fully advanced position before refitting the chain cover.

Replace

Rocker box side cover, magneto side cover, magneto chain case cover, sparking plug and sparking plug wire.

### VALVE TIMING Standard Heavyweight Models

Taken with valve .001" off its seat

#### Inlet valve timing.

Inlet valve opens 36° before top dead centre—350 c.c. models.

Inlet valve opens 18° before top dead centre—500 c.c. models.

Inlet valve closes 51° after bottom dead centre—350 c.c. models.

Inlet valve closes 69° after bottom dead centre—500 c.c. models.

#### Exhaust valve timing.

Exhaust valve opens 50° before bottom dead centre—All models.

Exhaust valve closes 30° after top dead centre—All models.

#### Camshaft timing marks.

Use mark 1 for exhaust cam—all touring models.

Use mark 2 for inlet cam—500 c.c. touring and competition models.

Use mark 2 for exhaust cam—all competition models.

Use mark 3 for inlet cam—350 c.c. touring models.

When checking the valve timing the tappet clearances must be set to

.016 inch so that the tappets may be well clear of the quietening curves of the camshafts.

The timing gears are marked to facilitate their replacement.

To re-set the valve timing, by using the marks on the gears, proceed as follows:—

Turn over the engine till the mark on the small timing pinion is in line with the centre of the inlet (rear) camshaft bush. Insert the inlet camshaft so that the No. 2 or No. 3 mark on it is in mesh with the mark on the small timing pinion, according to model.

Rotate the engine in a forward direction till the mark on the small timing pinion is in line with the centre of the exhaust (front) camshaft bush.

Insert the exhaust camshaft so that the No. 1 mark on it is in mesh with the mark on the small timing pinion.

### Trials Models

Inlet opens 26° before top dead centre.

Inlet closes 53° after bottom dead centre.

Exhaust opens 64° before bottom dead centre.

Exhaust closes 25° after top dead centre,

taken with 0.016" tappet clearance and with the valve 0.001" off its seat.

### ENGINE OVERHAUL 250 c.c. and 350 c.c. Lightweight Models

**Removing the engine from frame.** The engine with gear box can be removed as a complete unit—removing the gear box first makes handling easier. Disconnect battery wires as a precaution against fire.

Start by stripping down as described for "removing the cylinder and piston".

Remove drain plug from front chain case to drain oil.

Remove near side footrest and engine plate cover—two screws.

Remove four snap connectors on alternator cables.

Remove six chain case screws and inspection cap.

Remove chain case cover—with care to allow the cables to come through the rear portion of the case.

Remove three clutch springs—take away the pressure plate.

Remove gear box mainshaft nut securing clutch.

Remove nut fixing rotor on engine shaft—use a close fitting ring spanner.

When a duplex front chain is used remove the clutch and engine sprocket simultaneously as the chain is "endless". When a single chain is used take out the connecting link.

Remove three screws securing the rear portion of chaincase.

Remove fairing for timing cover 042053/4, pull out the contact breaker wire.

**Removing the gear box.**

Remove connecting link from rear chain, take out the clutch cable.

Remove kickstarter crank and gear pedal.

Remove gear box adjuster bolt 042394 also all nuts fixing right side

rear engine plate with distance pieces behind it. Release the two clamp nuts then take away the plate and the gear box.

Take out the engine by:

Removing five studs passing through the crankcase and frame.

Raise the rear end of the crankcase—pull it back and out of the frame.

If difficulty exists, take the machine off the central stand the frame will open and let the engine come out.

**Dismantling the engine.** Before dismantling, study the exploded view of the engine.

**Special tools required.**

(1) Extractor bolt for automatic ignition device 042247.

(2) Small timing pinion extractor 043332.

(3) Clutch withdrawal tool 040449—only required when clutch is a tight fit on the shaft.

**With engine removed from frame.**

Remove drain plugs from crankcase and oil reservoir.

Remove contact breaker base plate—use tool 042247.

Remove four bolts for cam housing—gently tap it to remove.

Remove nine bolts for reservoir, it will then come away.

Remove small timing pinion nut **RIGHT HAND THREAD** then strip down the timing gear in the following order.

(1) Camshaft.

(2) Camshaft distance piece—wide.

(3) Camshaft follower, exhaust.

(4) Camshaft distance piece—narrow.

(5) Camshaft follower, inlet.

**Warning.** An attempt to separate the crankcase halves, without first removing the oil pump plunger 042178 will result in serious damage, by making the crankcase beyond further use.

Remove oil pump guide pin 010079 and sleeve 010138.

Remove screwed plug and 'O' ring 042178.

Remove oil pump plunger 042104—insert a piece of rod in the spindle hole to extract it.

Remove felt filter cap 042058, take out the filter.

Remove six crankcase bolts 042035, one bolt 042036, also stud 016103—the timing case half can now be separated from drive side.

Remove the breather stator fixing tube at the rear of the crankcase.

On engines after number 8979 the stator is fixed by a bolt below the drive side bearings.

The crankcase must be heated to relieve the interference fit of the bearings in the crankcase—not above 200 centigrade, when the crankcase will come away leaving the ball bearing in the case.

Re-heat the case—use a drift to drive out the ball bearing.

Take off the breather stator from the shaft, watch for the key which must be removed before taking off the inner bearing.

**Dismantling the flywheels.** A flywheel separating tool is shown in Fig. 7. With one crank pin nut removed place the tool over the flywheels as shown—position the draw bolt. By screwing in the bolt the flywheel will come away from the crank pin.

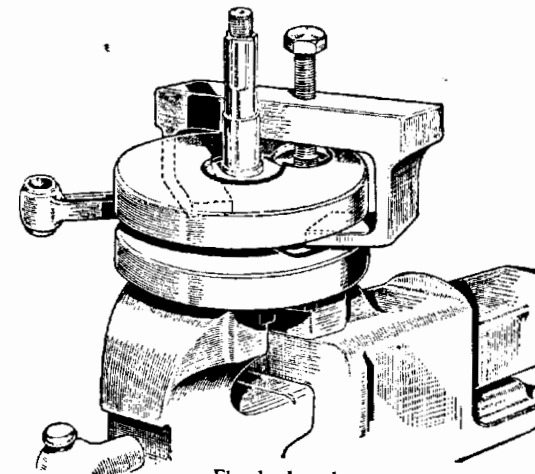

Flywheel tool

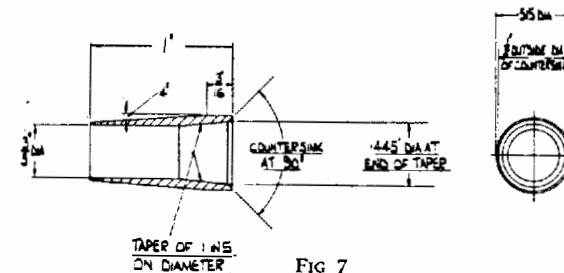

FIG 7

**Removing the flywheel shafts.** Both shafts are a force fit in the flywheels and are removed by using an arbour press.

**Removing the timing side bush.** Support the case with a suitable piece of tubing and press out the bush from inside the case—the retaining pin will come out with the bush.

**Removing the cam wheel bush 042101 in the cover.** First take out the oil seal 042183—press out the bush from inside the cover, warming the cover will make it easier to remove.

When re-fitting the bush locate the slot in it at 12 o'clock.

**Replacing the oil seal 042183.** The oil seal is refitted with the metal backing facing outwards, a simple tool to avoid damage to the seal when the cover is fitted is shown in Fig. 7.

**Assembling the flywheels.** The importance of using an arbour press to assemble the flywheels cannot be too highly stressed. To rely on tightening the crank pin nuts will result in a broken crank pin, due to the flywheels flexing when the engine is under load. It is for this reason that after fitting the crank pin, both flywheels must be forced together under a press, so that the shoulder of the crank pin is hard against the flywheel. It is after this operation that the nuts are tightened. The torque spanner setting when cast iron flywheels are used is 140 ft. lbs. With engines that have steel flywheels the torque setting is 190 ft. lbs.

If, after assembling the flywheels, the connecting rod is not free to rotate, this could be due to one or both drive shafts moving inwards and rubbing against the connecting rod. Drive home the shaft that is affected. The flywheels should run true, in centres, to a limit of .001" to .002" and no more.

**Refitting the timing side bush.** Locate and press in the bush, then fit the locating pin, designed to prevent the bush moving. Replacement bushes are sized to allow for contraction when in the crankcase. If the shaft will not enter, or is a tight fit, ream the bush to .8755" to .8750". The bush should be flush with the inside of the crankcase.

**Refitting the drive side bearings.** The crankcase should be gently heated to fit the bearings, assemble in the following order:

Fit the bearing 012542—nearest to the engine sprocket.

Fit the stator 043036—locate with the tube, or bolt whichever is fitted.

Fit the bearing ring in the crankcase—"peen" the ring in three places.

Fit the centre member for the bearing on the drive shaft, fit the key for the rotor 041021—then fit the rotor to engage with the key, apply oil to it.

Insert flywheels into the drive side crankcase.

Apply jointing compound—"Wellseal"—to crankcase joint, verify all oilways in the timing side crankcase are clear, then fit the case to the drive side half.

Pass the seven bolts through the crankcase and tighten.

Check the small bolt for the oil pump plunger 042046—the tip may have broken away. When renewing the "O" ring—fit this to the widest of the two rings. Insert the plug 042044 chamfered end first and locate it with the pin 042046 mentioned above.

**Fitting the oil pump plunger.** Apply some clean oil, insert the plunger into the crankcase to a depth of  $1\frac{1}{4}$ " from the screwed plug face. Check the end of the guide pin (which engages with the annular slot in the plunger) for wear at the top end. A small flat worn at this end will curtail, or cut off the oil supply to the rocker gear and a new pin must be fitted. Using extreme care, screw in the sleeve with the guide pin 010079—the reduced end goes inside the sleeve—and make sure that the guide pin engages with the annular groove in the plunger. Do not use force, move the plunger to engage the pin if necessary, use a spanner only when the sleeve is fully home. Failure to observe these precautions can ruin the plunger beyond further use.

Fit the housing plug 042045 with its washer. Firmly tighten as an air leak at this point will affect the oiling system.

**Fitting the timing gear.** Assemble as detailed in para VALVE TIMING.  
**Oil filters.** Before fitting ensure that the fabric filter is undamaged and is clean.

### 350 c.c. and 500 c.c. Heavyweight Models

**Removing the engine from frame.** If the engine has to be removed for dismantling, commence by following the instructions given for removing the cylinder and piston. To facilitate crankcase assembly removal then:

Disconnect two wires from the battery.

Disconnect both oil pipes (watch spanner manipulation at crankcase end) and drain oil tank.

Lever the oil pipes off (tank end) with a screwdriver or a piece of wood.

Disconnect four snap connectors for alternator wires and contact breaker cable, lift off the engine plate cover to expose connectors.

Remove rocker box oil pipe from crankcase. Remove timing cover 027093.

Remove 14 screws securing outer portion of chaincase.

Remove central nut for front chaincase, place a receptacle under chaincase to catch oil.

Remove outer portion, with extreme care, feeding the alternator wires through the rear portion of chaincase.

Remove nuts securing rotor to engine shaft.

Remove clutch springs and clutch pressure plate.

Remove nut on gearbox mainshaft securing clutch. An 'easy to make tool' to prevent the mainshaft moving is shown in Fig. 8.

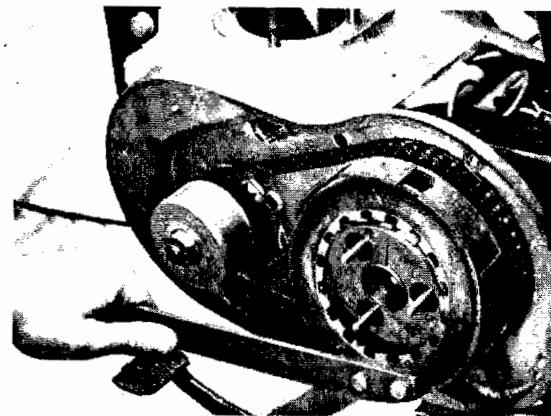

FIG 8

\*Remove front chain and take off clutch assembly (use clutch withdrawal tool 040449).

Remove rotor, engine sprocket, watch for distance piece behind it.  
Remove three countersunk screws fixing rear portion of chaincase to engine.

Remove crankcase breather pipe.  
Remove front engine plate bolts and take away engine plate.  
Remove both footrest arms.  
Remove three bolts passing through rear engine plate and crankcase.  
Release the top and bottom gearbox fixing nuts a few turns.  
Move the crankcase assembly forward, lift and take it out of the frame.  
**NOTE**—If a magneto is fitted, follow details given for removing Scrambler type engine.

**Warning:** When the engine has to be re-installed, connect the two oil pipes at the crankcase end first.

Screw home as far as possible the two nipple nuts by finger application, to avoid the risk of cross threading. Finally tighten without undue force with suitable spanner.

**Removing tappet guides.** Both guides are a force fit in the crankcase, the guide with its tappet are removed together from inside the timing chest. It is preferable to effect this operation with the engine in a dismantled state, with both halves of the crankcase bolted together to avoid distortion and give additional support.

Heat the crankcase in the vicinity of the guides, sufficiently to enable them to be drifted out. Use the same method to refit the tappet and guide. The two dowel pins for the cover can fall out, when the crankcase is heated. When the guide is correctly located, the outside diameter is just flush with the crankcase face.

**Dismantling the rocker box.** The design of the rocker box is basically the same on all single cylinder models. Some Lightweight 250 c.c. models do not use a valve lifter, but a later type rocker box 044034 can be used on this type of engine. Use the following parts for the valve lifter assembly:—

Valve lifter lever 013969.  
Valve lifter spring 044035.  
Valve lifter screw 000451.  
Valve lifter washer 000039.  
Valve lifter lever ring 014523.  
Valve lifter cable 026254.  
Valve lifter lever assembly 026239.

The rocker box is supplied with bushes. The existing rockers, etc., can be transferred.

It is best to refer to Fig. 3 to understand the assembly sequence of the parts used in the rocker box. To dismantle, place a box spanner (that will fit the nut 000003) firmly in a vice. Invert the rocker box, place one of the two rocker spindle nuts into the box spanner.

Using an open end spanner, release and remove the rocker axle nut inside the rocker box.

Using a soft drift, tap out the axle, when the inside rocker will drop

off the spindle. The outside rocker with spindle can be pulled out together with the steel sleeve 017292.

Either one or two felt sealing rings used midway between the two rocker axle bushes can be prised out with a sharp pointed tool. As a guide, measure the protrusion of the inner bushes before removal.

**Removing the rocker bushes.** If the rocker box is slightly heated, the rocker bushes can be drifted out without difficulty.

**Refitting the rocker bushes.** It should be explained that the location of the rocker bushes controls the end play between the bushes and the rockers. Re-heat the rocker box and fit one of the inner bushes, chamfered end first. The bush should be to the amount measured before dismantling, which usually is approximately  $\frac{1}{32}$ ". With the four bushes assembled and if new ones are used, they should be reamed to  $\frac{1}{32}$ " + .00075" — .00050" in situ. Introduce the felt ring(s) into the groove. A taper mandrel inserted into the felt ring is desirable to compress the felt to enable the steel sleeve to pass through. Put the steel sleeve (with some oil on it) over the rocker spindle with the outside rocker attached, carefully work the assembly through the bushes and felt ring.

Refit the inner rocker and using again the box spanner firmly tighten both nuts. If the rocker assembly is tight to move, a light tap on the outer end of the rocker spindle with a light hammer will move the bush and give a free movement. The end play should just be discernible. If the end play is in excess, take out the spindle assembly and tap outwards one of the bushes.

**NOTE**—The rocker arm valve end should be central with the valve stem.

**Separating the crankcase.** With the crankcase out of the frame start by:

Removing oil pump guide pin and sleeve (6) Fig. 9.  
Removing four bolts securing cap for oil pump plunger and pull out the plunger.

Removing bottom and front crankcase bolt.  
The crankcase can now be separated, as the small timing pinion will pass through the timing side bush; the pinion can be dealt with later.

**Separating the flywheels.** To do this use the tool and method described for the 250 c.c. Scrambler models.

**Removing small timing pinion.** The nut securing this pinion has a left-hand thread. The pinion is a taper fit on the shaft and usually requires an extractor tool B2151. When using any kind of extractor, apply light pressure on the withdrawal part of the tool, then give the end a sharp blow with a hammer, the shock will dislodge the pinion. A new pinion will absorb backlash and cure timing gear rattle.

**Removing the drive side bearings.** Gently heat the drive side crankcase and drift out both bearings. Check both bearings for roughness caused by pitted race tracks. Renew the bearings at the slightest sign of roughness, the bearing should spin by hand rotation smoothly and quietly.

**Removing the timing side bush.** Support the half crankcase firmly, press out bush from timing cover end, the locating peg will come out with bush. If a new bush is used, ream in situ to 1.125" + .0005" — .0000". Replace locating peg when bush is in position.

**Camshaft bushes.** These rarely wear, do not be misled by wagging the

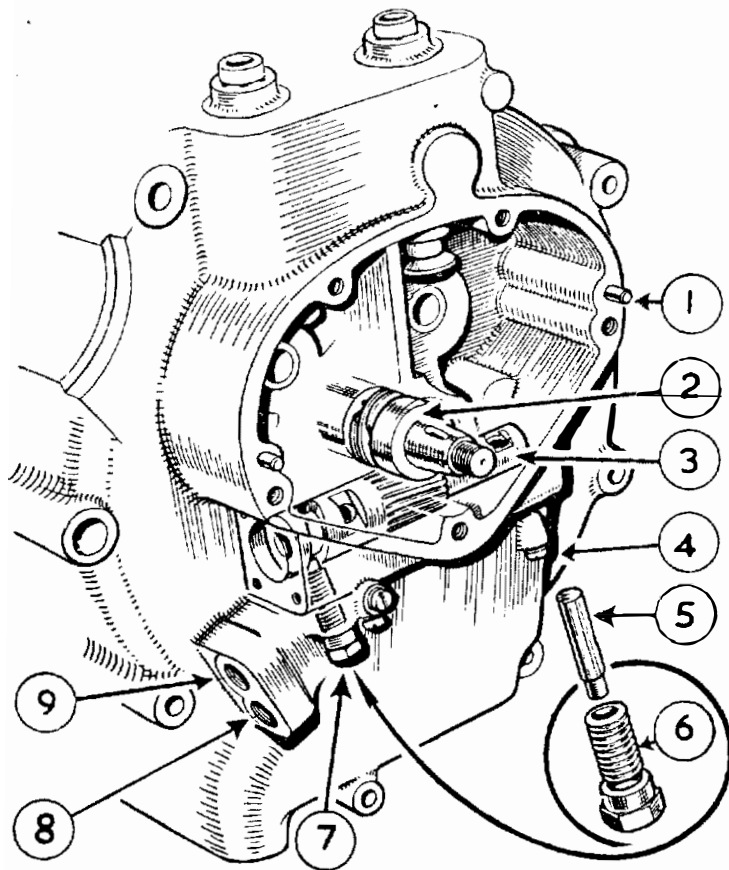

FIG 9

The rotating oil pump plunger is here shown *in situ*, together with the guide screw which registers in the plunger profiled groove, thereby providing the reciprocating movement.

Key to FIG 9

- 1 Dowel peg, locating timing gear cover.
- 2 Timing side flywheel axle with integral gear for driving oil pump plunger.
- 3 Oil pump plunger.
- 4 Screw (one or three) with fibre washer, plugging oil passages cast in crankcase.
- 5 Guide pin, for oil pump plunger. Inserted relieved tip downward as shown.
- 6 Screwed body to accommodate the oil pump plunger guide pin.
- 7 Body, with guide pin in position engaged in profiled cam groove of oil pump plunger.
- 8 Tapped hole, for pipe feeding oil to oil pump.
- 9 Tapped hole, for pipe returning oil to oil tank.

camshaft supported in the back bush only, the bush is short and some movement will be manifest even with a new bush. Press in new bushes from inside the crankcase with oil holes lined up. Both bushes are located flush with the crankcase. When new they should be reamed *in situ* to  $\frac{1}{4} + .0005" - .0005"$ . If new bushes are used, assemble the cam-wheels, fit the timing cover tightly and check cam-wheel for end float and free movement. Use a shim washer 016847 to absorb end movement. End play can dislodge the metal cap on timing cover by hydraulic effect.

**Reassembling the flywheels.** If attention to the big end assembly is needed, it is preferable, wherever possible, to use a factory serviced con rod, as the big end liner, also small end bush, is finished ground *in situ* to ensure concentricity. Alternatively, use a lapping tool A8078 for the new con rod liner after it has been replaced. The degree of interference fit between the liner and the con rod controls the contraction of the liner. Although liners issued as spares are finished ground to a pre-determined size, concentricity cannot be guaranteed, hence the use of a lapping tool in some cases.

**Removing the flywheel shafts.** Both shafts are a press fit in the flywheels. Remove in turn each shaft nut, support the flywheel and press out with an arbour press, or similar equipment.

**Refitting the shaft.** The correct location of both shafts is of vital importance. If the drive shaft is incorrectly located, the alternator output will be adversely affected. Looking at the outside of the flywheel, the shaft should be inserted with the keyway for the rotor pointing forwards (approximately 9 o'clock).

If the timing side shaft is incorrectly located, the oil supply can be curtailed (with damage to the oil pump plunger), also the valve timing will be deranged. Use a pencil and scribe a line on the shank of the shaft dead central with the oil hole. Offer up the shaft with the scribed line central with the oil hole in the flywheel. Tap the end of the shaft to prevent it moving then press firmly home with a suitable press. To check location of shaft, fit the small pinion, the mark on the pinion should be exactly at 12 o'clock.

Tighten both shaft nuts with torque spanner set to 190 ft. lbs.

**Fitting the crankpin.** If the engine has covered considerable mileage prior to dismantling, and a new crankpin is needed, the roller cage should be replaced also. Metal or abrasive can become embedded in the soft metal used for the cage, which with further use can cause abrasive wear. Verify oil holes in the crankpin are clear and clean before fitting. Scribe a pencil line (as described for timing shaft) on crankpin shank, enter the crankpin with the line central with oil holes in timing side flywheel and tap it home. Press the crankpin into the flywheel until it lightly abuts against the crankpin sleeve. Fit the roller cage and fill with rollers (30) that have been checked for uniformity in diameter.

Apply some engine oil to the con rod liner, also rollers, or a little Molybdenum Disulphide preparation will provide immediate lubrication. Offer up the drive side flywheel, roughly align both wheels with a straight edge placed on the outside diameter of both wheels. Place both wheels under an arbour press and force each flywheel firmly against the crankpin sleeve. Run down both crankpin nuts evenly (do not tighten one nut at a time).

Finally tighten both nuts with a torque spanner set to 190 ft. lbs. Set both flywheels with shaft to run true to .001" to .002" error.

**Reassembling the engine.** When refitting the driving side bearings heat the crankcase, introduce the bearing 026762 squarely with the housing, then washer 021859 followed by bearing 021872. Use a mandrel or old drive side shaft to line up bearings. The inner member of both bearings should rotate independently to avoid end loading. Move outer bearing to free off.

Remove every trace of jointing compound from the crankcase joints, also the cylinder base faces. Apply some jointing compound of the non-flaking type, such as "Wellseal", to both crankcase faces. Use oil on the crankcase bearings, put both cases together, pass three bolts through the crankcase evenly spaced (as a temporary measure). Set the cylinder base face square and even (the cylinder can be fitted temporarily for this purpose) then firmly tighten the three crankcase bolts. The flywheel should rotate by hand application freely without tight places if the flywheel shafts are running true. Check for end float, which should be .012" minimum between the flywheels and crankcase. Bearing 026762 is a C3 fit.

**Refitting the oil pump plunger.** First renew the paper gaskets on the pump end caps, stick the gaskets to the plates with jointing compound.

Remove burrs or particles of old gasket from crankcase faces. Take up the oil pump plunger, oil it and insert in crankcase. Clean the interior of screwed body (6) Fig. 9. Oil and insert guide pin (5) as illustrated, the pin should revolve freely. Fit the screwed body and pin with extreme care to ensure the guide pin is located in the annular groove in the pump plunger, using the finger to do so. It may be necessary to revolve the flywheels to locate the pin. The screwed body can be finally tightened with a spanner. *"Failure to observe these important instructions can ruin the pump gear beyond further use".* Now fit the two end caps.

**Fitting the camshafts.** Refer to details on valve timing.

**Refitting the timing gear cover.** If there is evidence of oil in the contact breaker compartment, the oil seal 024287 should be replaced. To prevent

damage to the oil seal during the process of refitting the cover, a guide tool is used. The tool is fitted over the shaft for the cam wheel, with a little oil on it to guide the seal over the shaft. The seal should be fitted in the cover with the metal backing facing outwards. Clean the face of the cover and stick a new gasket to it. The cover 024016 can now be put back with three screws 000482.

**Resetting the ignition timing.** Fit the automatic timing control (make sure the weights move freely, apply a spot of oil on the pivot pins) and the contact plate, and roughly assemble the timing control. Set the ignition before fitting the cylinder head as the piston travel can be measured more easily.

Follow details for setting ignition timing previously described.

### 1962 350 c.c. Short Stroke Engine

The general arrangement of the standard and sports versions are similar in respect of engine design. The bottom part of the engine, excluding the flywheels, is similar to the earlier type engine.

Service details given for the 350 c.c. Heavyweight model apply also to this later type engine.

The push rod tunnels are integral with the cylinder, with oil seals in a recess in the cylinder barrel. Scrambler type valve springs are also used for high r.p.m. The compression ratio is 8.5:1.

This engine develops considerably more b.h.p. than the earlier type.

A list of parts that differ from the earlier type are tabulated:—

350 c.c. G3-16	(New Parts)
028106 R/Box steady bolt	014044 Valve spring collar inlet and exhaust
029318 R/Box steady bolt	014042 Valve spring collet inlet
028100 Head gasket	014039 Valve spring collet exhaust
028596 Push rod assy.	015422 Rocker box
022518 Push rod rubber	028123 Carburetter
028104 Cylinder head	041014 Carburetter O ring
026030 Inlet guide	015875 Carburetter spacer
024519 Exhaust guide	028107 Piston
026028 Inlet valve	028114 Piston ring chrome
028105 Exhaust valve	028115 Piston ring plain
026861 Valve spring	028116 Piston ring scraper
026862 Valve spring	028113 Gudgeon pin
028531 Crankcase assd.	028097 Flywheel T/S
028102 Cylinder base stud	028096 Flywheel D/S
028095 Cylinder barrel	015351 Cylinder stud nut
028101 Cylinder base gasket	042157 Cylinder stud washer

### Scrambler Models CS and TCS

Basically the design of the two above models is identical, with the exception of the bore and stroke.

‡ The 500 c.c. version has a bore size of 86 mm. and 85.5 mm. stroke, as opposed to 596 c.c. engine, which has a bore size of 89 mm. and 96 mm. stroke. The peak r.p.m. of the 500 c.c. engine is 6,200, the larger capacity engine peaks at 5,500 r.p.m.

A number of engines were fitted with a Monobloc type carburetter with a bore size of  $1\frac{3}{8}$ ".

Where a sudden change in diameter between the carburetter outlet, the carburetter spacer and the inlet port occurs, the parts or whatever part is affected should be flared out or blended, to overcome any abrupt change in diameter.

The use of G.P. type carburetter with a bore size of  $1\frac{3}{8}$ " with a parallel inlet tract will increase the volumetric efficiency of the engine. Attention is drawn to the use of late type camshafts in early type engines, see paragraph on 'valve timing'.

**Port polishing.** If, during the process of tuning, the ports are polished, the metal removed must be of the smallest amount possible to avoid drastic changes in the port shape. This applies particularly to the metal immediately below the valve inserts, which could cause the inserts to collapse. It is usually considered that a nice bright polished finish to the sphere of the cylinder head and piston crown is essential for best results. This is not so, for the ideal condition of the combustion chamber is when it has reached a nice black or ebony-like finish. This probably explains why it takes a little time for the engine to settle down before coming on 'full song'. Therefore the sphere of the head should not be disturbed, other than to remove soft carbon formed near the exhaust valve. If the engine is 'set up' correctly and under race conditions, the carbon formation should be negligible.

**Compression ratio.** The normal compression ratio on the CS and TCS engines is 8.7 to 1. An alternative piston giving a ratio of 12 to 1 is available. With this piston the ignition is put back to a maximum of 34° Straight petrol can be used, octane 100 (research method). A suitable spark plug with a high heat factor is essential.

**1957-1959 engines.** The cylinder head and piston introduced for the 1960-61 season is more efficient than the earlier type. These new parts can be used together on earlier engines, but not separately.

The big end is robust in construction, the crankpin is materially and dimensionally identical to the G50 race model Matchless. As with the 250 c.c. Scrambler Model, it is of paramount importance that the big end is rigidly assembled, to avoid power loss, apart from the risk of breakage. In consequence, if renewals are made, both flywheels must be forced firmly against the two shoulders of the crankpin, by using a press designed for this work. In fact a 12-ton press is used in the factory to assemble the flywheels. An attempt to drive the flywheels together and rely on nut tightness can only lead to mechanical trouble.

**Big end wear.** Wear on both edges of the crankpin is due to inertia wear, caused by the crankpin cage rubbing on the crankpin. This becomes most acute when the engine is run at high r.p.m. with little or no load. This wear does not affect or cause movement in the big end assembly. Wear on the roller path of the crankpin can be due to abrasive impregnated in the

big end cage. In the event of damage to the crankpin, by reason of detonation, due to excess ignition advance, pre-ignition (soft plug), or unsuitable fuel, it is essential to replace the roller cage as well as other big end parts. The crankpin and liner for con rod have a mirror like finish (5 micros) and are made to close limits. To ensure uniformity each roller should be measured by micrometer and selected to a uniform diameter; 1962 big end assembly uses 28  $\frac{1}{4}$ "  $\times$   $\frac{1}{4}$ " rollers.

**Timing side shaft.** Normally the thread for the small timing pinion is left hand. A number of engines were issued with right-hand threads, these shafts can be identified by the use of a tab, or lock washer, between the pinion and pinion retaining nut. An improved type shaft was introduced for the 1960 models, identifiable by a wider gear. Should wear develop on the oil pump plunger, the new type shaft should be used.

**Crankcase bearings.** The bearings fitted to the drive side of the crankcase are usually trouble free. If a Scrambler Model is used extensively for racing, or when the power output has been increased by tuning with the fitment of an ultra high compression piston, a heavy duty roller type bearing can be used in place of the ball type. The new bearing is of the Hoffman type RMS 10 ( $2\frac{1}{2}$ "  $\times$  1"  $\times$   $\frac{3}{4}$ " ) and should be fitted next to the flywheel. When the bearing is pressed into position, the crankcase should be peened alongside the outer bearing sleeve in three equi-distant positions, to keep the sleeve in location.

**Timing side bush.** It must be mentioned that the outer end (timing gear side) of this bush is swaged out to make it slightly bell mouth, thus preventing the bush from moving inwards towards the flywheel. This means that the bush must be extracted by pressure on the flywheel end of the bush to avoid damage to the crankcase during removal.

**Cylinder head and barrel joint.** Normally there is an annular space between the spigot on the cylinder barrel and the small face on the cylinder, when the cylinder head is assembled. This space can be eliminated by individual machining, assuming the necessary machining facilities are available. To do this, machine back the wide face on the cylinder head, leaving a gap of .001" between the small recess in the cylinder head and the narrow spigot on the cylinder barrel. Use grinding paste on the wide face of the cylinder head, also in the small recess. Grind the head on to the cylinder barrel until both faces on the cylinder head are mated to the cylinder barrel to give a gas-tight joint. Should an oil leak develop from the cylinder head face, regrind the spigot *situ* only.

**Dismantling the Scrambler engine.** Follow the details given for the Heavyweight Single Cylinder Models, as the sequence is identical with the exception of the cylinder head bolts. Check the cylinder head steady stay for ovality in the bolt holes caused by movement due to looseness, and get the holes built up by weld and re-drill or replace the stay. Engine movement due to torque can cause vibration.

**Removing the engine from frame.** With the cylinder head and barrel, also piston removed, start by:

Removing magneto case outer cover (see note).

Removing magneto chain with both sprockets.



Removing magneto control cable handlebar end and contact breaker vent pipe and front engine plate.

Removing both oil pipes (be careful with spanner manipulation at crankcase end).

Removing outer portion front chain case.

Removing clutch assembly, engine sprocket and chain (see note).

Removing rear portion front chain case.

Removing crankcase release pipe.

Removing bolts passing through rear engine plates and crankcase, then loosen top and bottom gear box fixing bolts, loosen also footrest rod and central stand pivot bolt which tend to clamp the crankcase.

Removing bottom front engine bolt.

Removing crankcase assembly from frame. When a duplex tube frame is not used, wheel machine off the stand, the frame will open and facilitate removal of crankcase.

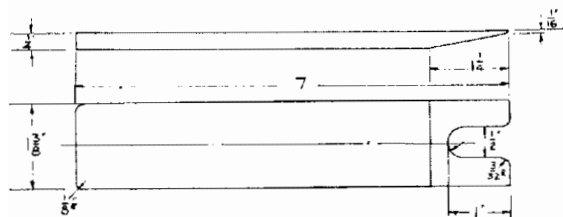

FIG 10 Magneto sprocket remover

**NOTE**—Use a tyre lever with one end bent at right angle to prise off the lower magneto sprocket. To remove top sprocket, slacken off all timing cover screws, use tool B 4018 (see Fig. 10), inserted between magneto sprocket and magneto body. With the armature nut removed, a light tap on the tool will dislodge sprocket. A tool to prevent the engine turning (top gear engaged) whilst unscrewing the gear box mainshaft nut and also engine sprocket nut is shown in Fig. 8, which is easy to fabricate.

**Separating the crankcase.** Before attempting to separate the crankcase, the oil pump plunger must be removed by taking off the cap at the rear end of the pump plunger housing, then remove the screwed body (No. 6, Fig. 9), and guide pin (5). Insert a piece of stout wire or wheel spoke in the plunger hole and pull out the pump plunger.

**Removing the small timing pinion.** This pinion is a taper fit on the shaft and needs a tool or puller to extract it from the shaft. Put the tool in position and lightly tighten the draw bolt (do not over tighten), then give the end of the draw bolt a sharp blow with a light hammer, the pinion will then come away from the shaft.

**Separating the flywheels.** The flywheel separating tool B 2140 as described for the 250 c.c. model, can also be used for the Scrambler. As an

alternative, use an Arbour press with one flywheel supported by two stout steel bars placed on four blocks, which is the best method if suitable equipment is available.

**Removing the timing side bush.** Firmly support the crankcase on the timing cover end, press out the bush from inside the crankcase. To fit a new bush, reverse the crankcase, press in the new bush, the inner edge should be flush with the crankcase. This bush is fine bored in production with the bush in position. The new bush should be reamed to .8752" to .8757".

**Timing side bearing sleeve (022352).** This is a press fit on the shaft, the normal outside diameter is 1.2581" to 1.2585".

**Timing side bearing (022351).** To remove bearing sleeve, apply heat to the crankcase, drop the crankcase on the bench, when the bearing sleeve will fall out.

**Camshaft bushes.** See details given for 'Heavyweight Single Cylinder Models'.

**Rocker box.** For dismantling instructions refer to 'Heavyweight Single Cylinder Models'.

**Assembling the flywheels.** These must be assembled with a suitable hand press. Tighten the crankpin nuts with a torque spanner set to 240 ft. lbs. The shafts should run true to .001" to .002".

**Cylinder head joint.** As a gasket is not used, the joint is remade by grinding the cylinder head on to the barrel by moving the head to and fro through an arc of about 30° and not in a full circular motion. Continue grinding until a full matt surface on both parts is shown.

**Valve timing.** Up to 1959 cam wheels marked SH were used with part number 018833 and 022567 for the inlet and exhaust respectively. Both cam wheels are marked for correct assembly. Install the inlet cam with the No. 2 mark to register with the mark on the small pinion. Use No. 1 mark for exhaust to also register with mark on small pinion.

The push rod clearance for these cams is *nil* for the inlet and .005" for the exhaust (engine cold). The inlet push rod should be just free to revolve by finger application. The clearance of .005" for the exhaust represents one flat on the adjusting screw away from the *nil* clearance setting. Position the engine for push rod adjustment as described for Touring Heavyweight Models.

The valve timing on average is as follows:

Inlet opens	59° b.t.d.c.
„ closes	69° a.b.d.c.
Exhaust opens	74° b.b.d.c.
„ closes	48° a.t.d.c.

These readings are taken with the valve .001" off its seat with running push rod clearance. The valve lift is .375".

**Valve timing—1960.** A more efficient type of inlet cam was introduced for and after the 1960 season. The inlet cam is marked C1, Part No. 024534, and is used in conjunction with the 1959 exhaust cam 022567. The valve timing with the new cam allows the inlet to open at 67° b.t.d.c. and to close at 80° a.b.d.c. with a *nil* clearance and the valve .001" off its seat. The valve lift is .428".

**Fitting new type camshafts.** The special inlet cam No. 024534 first introduced in 1960 can be fitted to earlier type engines providing the crankcase alongside the timing side bush is machined for clearance, as the valve lift is higher. The inlet tappet guide should also be reduced in length (inside the timing cover) to the extent of  $\frac{1}{8}$ ", also use inlet valve guide 026030.

**G80 R Models.** Engines for this model use the inlet cam 024534 and a special exhaust cam marked CE Part No. 024535, the exhaust valve opens 83° b.b.d.c. and closes 60° a.t.d.c.

The valve lift is .445" (use No. 1 mark). This combination is best suited where high r.p.m. is required for short circuit events, or in drag events providing the engine is taken up to 3,500 r.p.m. before take off. Where good torque is needed at comparatively low r.p.m. the 1960 set up is the best arrangement.

**Valve springs.** These springs (which are shot blasted after manufacture) must be free from bruises or blemishes, which can cause a spring breakage. The free length (unassembled) taken between the wire centre for the spring leg and the portion which engages with the valve spring collar is  $1\frac{1}{32}$ ".

**Valve spring collets.** Must be free from burrs and a good tight taper fit in the valve spring collar. Loose fitting collets can cause a valve breakage.

**1962 Engines.** An improved type of valve operating mechanism is used on these engines, comprising the following parts:

(1) Long push rods	2 off	028185
(2) Short tappets	"	028182
(3) Tappet guides	"	028184
(4) Inlet rocker	1 off	042043
(5) Inlet camshaft		028191
(6) Exhaust camshaft	"	028193

The new type parts can be used on earlier type engines.

#### 1964 Model G85 CS; G80 CS; 350 c.c. and 500 c.c. Standard Models

**Lubrication.** A gear type oil pump driven by the worm gear on the timing side axle is retained by two studs, and secured by two nuts. A conical shaped heat resisting rubber seal is attached to the pump body, where it abuts against a drilling in the timing cover.

From here oil is fed to the big end via a steel quill, which enters the timing side axle, lubricating the big end assembly. A by-pass from the main feed, taken from the timing cover conveys oil to positively lubricate the rocker gear. The oil supply is regulated in a manner described for the earlier type engines.

**The oil seal.** It is important that the oil seal is under light pressure when the timing cover is fitted, for a reason that is self evident. When both valves are closed and the timing cover fitted, the pressure of the seal should move the cover outwards, making a gap of about .010". If pressure does not exist, use packing shims, provided for this purpose, between the seal and the pump body. Conversely too much pressure can mutilate the seal and cause oil leakage.

**The oil pump.** The face of the oil pump body, where it joins the crankcase, must be perfectly flat also free from bruises and blemish; otherwise the oil "pick up" from the pump will be curtailed, as the pump will suck air at this point. Use a little Wellseal as jointing compound on the pump body when fitting.

There are more than one type of oil pump worm nut and pump pinions. If at any time new parts are fitted, check the new ones against the old ones before they are installed. The pump pinions are of the three start type. If the pump is dismantled, on assembly make sure the end plates do not protrude over the pump body; they should be just below the pump body.

**Check valve.** A simple check valve (Fig. 11) is provided to prevent oil seeping into the crankcase when the engine is stationary.

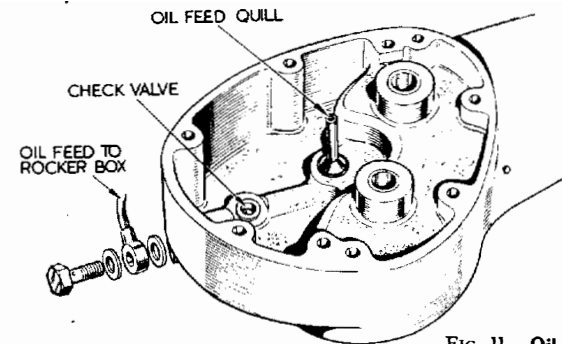

FIG 11 Oil check valve

**The bearing oil seal.** A thin bronze bush is used in the timing side crankcase, this does not constitute a bearing as it is simply an oil seal to stop oil leaking past the roller bearing. 1964 models only.

**Crankcase bearings.** The design of the driving side bearings is unaltered. Details for removal as described for earlier models still apply. A flanged type roller bearing is now used in the timing side of the engine on all single cylinder engines. The bearing sleeve is an interference fit in the crankcase, to take it out the crankcase must be gently heated, then the action of dropping the case on to a flat wood bench will dislodge the sleeve.

**Separating the crankcase.** First take off the oil pump worm drive nut which has a *left hand thread*. Take off the oil pump, retained by two nuts. Remove the small timing pinion, which now has a parallel bore. With all the bolts passing through the crankcase taken out the case can be parted, the inner member for the roller bearing will remain on its shaft.

**The flywheels.** To take off the inner member for the roller bearing use two taper steel wedges behind the bearing, once a gap is formed a puller can be used to extract the bearing member from its shaft.

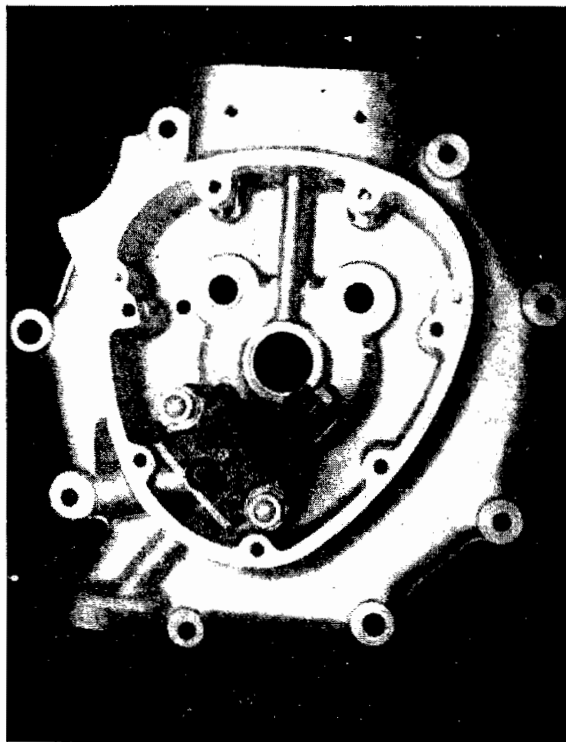

FIG 12 1964 crankcase

**Tappets and guides.** The timing side crankcase tappet guide *in situ* has two locating diameters  $\frac{1}{4}$ " wide at the top and bottom of the guide housing. The guides are located by a grub screw in register with a vee shaped groove machined circumferentially on the outside diameter of the guide. As the tappet foot is larger than the outside diameter of the guide, the tappet must be taken out from *inside* the timing chest, after removing the guide.

**Removing the tappets.** With the push rods, timing cover, oil pump, and cam gear removed, take out the grub screws, warm the crankcase, then push the tappet and guide upwards until the guide is clear, then take out the tappet from inside the timing chest. The short interference fit makes it easier to remove the guides.

**Fitting tappets and guides.** Warm the crankcase, pass the tappet up the guide hole and put on it the tappet guide. Press the guide home until the edge of the large diameter is just flush with the crankcase face, the vee shaped groove should now register with the grub screw hole, fit the screws.

**Timing gear.** The cam on all single cylinder models for 1964 will not interchange with 1963. Single marking is used on all cams, and for identification each cam wheel is marked with the factory part number. The 500 c.c. scrambler inlet cam is 030124, exhaust 030125. Inlet cam for the 350 c.c. is 030121, the exhaust is 030123. For the 500 c.c. standard engine the inlet cam is 030122, and for the same engine the exhaust is 030123 (same as the 350 c.c.).

**500 c.c. Scrambler Model.** The alternative piston to give a ratio of 12 to 1 is suitable for the new engine, for use with octane 100 fuel. When this piston is used the ignition timing must be put back to 33° to 34° full advance. For long distance events, the use of a compression plate .050" thick should be used, to maintain engine efficiency.

**Ignition timing all 1964/65 singles.**

Maximum advance 350 c.c.	34° (8.9 mm.)
500 c.c.	38° (10.98 mm.)
" " 500 c.c. Scrambler	38° (10.98 mm.)

All with the ignition unit fully advanced.

On coil ignition models the ignition unit can be advanced by using a tool in the slot provided in the end of the cam.

**Carburettor settings.**

1964/65 350 c.c. models

Type No. 389/208  
Main jet, 260 (with or without air filter)  
Slide, 3  
Pilot jet, 25  
Needle jet, .1065  
Needle position, central notch

1964/65 500 c.c. model

Type No. 389/209  
Main jet, 290 (with or without air filter)  
Slide, 3.5  
Pilot jet, 25  
Needle jet, .106  
Needle position, central notch

1964/65 500 c.c. Scrambler

Type No. G.P.5 ( $1\frac{1}{8}$ " choke)  
Main jet, 310 (with air cleaner 290)  
Air jet, .125"  
Slide, 6  
Needle, G.P.6, 5th notch.

## THE GEAR BOX 250 c.c. and 350 c.c. Lightweight Models

It will be seen in Fig. 13 that the gear box internals are situated above the centre line of the gear box shell. It is for this reason that at least three pints of engine oil must be filled and maintained for satisfactory lubrication.

### POSSIBLE FAULTS

**Top gear disengages.** This is most likely to occur on early type gear boxes before 7988 (250 c.c.) and 2300 (350 c.c.).

To rectify, discard the sleeve gear 041273 and sliding gear 041276 as shown in Fig. 3. Replace the sleeve gear with modified type 044075, also sliding gear 044076, which use undercut dogs for positive engagement. Should the fault develop on a later type gear box, the plunger 042835 may be damaged on the extreme end, or the spring for plunger 040045 is weak allowing the gear to disengage. Both gears must be changed to convert.

**Third gear only disengages.** The only remedy is to renew the two third gear pinions 041276 and 041277. Usually this is due to bad gear changing and possibly clutch drag.

**Bottom gear only disengages.** This can only be due to end play between the first gear pinion and kickstarter bush. To remedy, use a shim washer .020" thick placed over the layshaft between the pinion and kickstarter bush.

**Difficulty in selecting the gears.** Usually due to a distorted pawl spring 041327 preventing the pawl from rocking.

**Gear pedal does not centralise.** The footchange pedal spring is broken. Replace with improved cross over type 043453. Separate the legs when fitting.

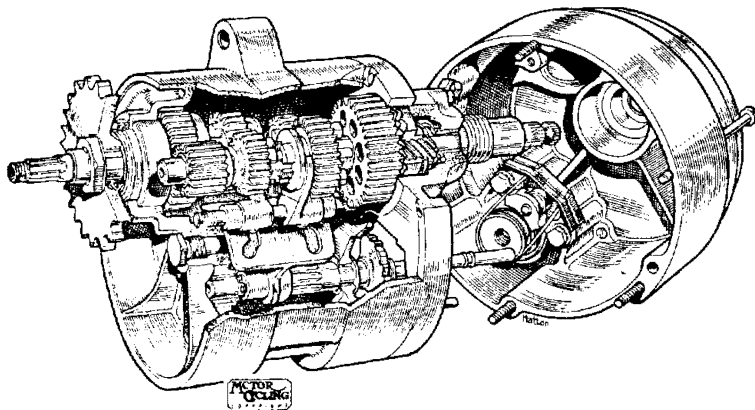

FIG 13 Lightweight gearbox with end cover removed

**First gear modification.** In gear boxes made before number G8603 (250 c.c. model) and M2701 (350 c.c. model) a plain layshaft first gear 041291 was used. This is superseded by a bushed pinion 044080. The new first gear can be used with the existing second gear pinion.

**Wear on kickstarter axle bush.** Only likely to occur on early models with gear box numbers before G6014. This can happen if the kickstarter return spring 040043 is overwound, which tends to pre-load the kickstarter bush against the first gear pinion. Gear boxes after the above number are fitted with a circlip 042900 encircling the kickstarter axle 042130 with a thrust washer 042901 to prevent pre-loading also wear on the axle bush. The new parts can be fitted to earlier type gear boxes.

**Oil leaks.** Two metal discs or core plugs are used to seal the aperture for the layshaft and quadrant spindle. These discs are a press fit in the gear box shell.

To rectify an oil leak from this part of the gear box it is necessary to take away the primary drive and rear portion of the front chaincase as described in removing the engine. Take out the gear box internals to drive out the discs and use replacements. Clean all traces of oil from the two apertures, apply jointing compound and tap the new discs into position. Allow plenty of time for the jointing compound to set before refilling gear box with oil.

**Oil leaks from end covers.** Can only be due to a broken or deformed gasket. Stick the gasket with jointing compound to the gear box shell before refitting the cover.

**Dismantling the gear box.** (All nuts are right-hand, except rear chain sprocket nut 041271.) With the gear box in the frame and clutch removed:

Remove exhaust pipe and silencer in one piece.

Remove right side footrest arm.

Remove gear indicator bolt 040137.

Remove gear change pedal, by releasing the pinch bolt.

Remove kickstarter crank bolt and nut, pull off the crank.

Remove four screws securing the fairing and take it away.

**Gear box end cover.** Take out the gear box drain plug, catch oil in a suitable receptacle.

Remove ratchet nut 041340 and ratchet 041283.

Remove six screws securing end cover, take off cover then remove ratchet and nut. The ratchet cannot be removed without taking off the cover. See Fig. 3.

**Gear box inner cover.** Remove clutch inner cable from lever.

Remove, by unscrewing clutch body lock ring 041280, use a soft drift and hammer.

Remove clutch operating body 042141 (watch for  $\frac{3}{8}$ " ball inside).

Remove mainshaft nut 041265.

Remove ratchet nut 041340 and washer.

The cover can now be removed exposing internals.

**Removing gear box internals.** Remove footchange quadrant 041334 with spindle assembled.

Remove, by unscrewing selector fork shaft 041345 (use a spanner on the two flats),

Remove gear cluster with mainshaft, layshaft and two striker forks.

The plunger 042835 together with its spring 040045 will remain in the gear box shell.

**Removing sleeve gear and sprocket.** Remove the rear chain. The sleeve gear sprocket nut 041271 has a *left-hand thread*. As the sprocket on the sleeve gear is subject to reversal by accelerating and decelerating the sprocket nut must be positively tight. In consequence the sprocket 041269 must be firmly held during the process of unscrewing, or tightening the nut. A chain bar is easy to fabricate. Use a short length of  $\frac{1}{2}$ " x .305" chain attached to a bar of suitable length, which is the best medium of holding the sprocket.

Turn back or flatten the tab washer between the nut and sprocket. Use a well fitting ring spanner  $1\frac{1}{2}$ " across the flats to release the nut.

**Removing the sleeve gear.** With the sprocket removed, press or gently tap the gear into the gear box shell.

**Removing sleeve gear bearing.** Prise out the oil seal, note the way it is fitted. Use a suitable drift to drive out the roller bearing. The distance piece 041391 will remain in gear box shell.

Remove bearings from gear box shell. Push out the two metal caps 041394/5 then drift out the layshaft bush 041289 and bush for footchange spindle 041307.

It is most unlikely that the spindle bush will be affected by wear.

**NOTE**—The roller bearings for the sleeve gear are self-aligning and can be waggled about when unsupported by the mainshafts. This can give an erroneous impression that the bearing is badly worn.

**Removing bearing from inner cover.** Support firmly the cover and press out the bush 041299. The kickstarter axle bush 041298 goes into a blind hole. Screw a coarse thread tap into the bush, and pull out the bush.

There is a peg to locate the clutch body 042141, watch this, when using a drift to extract the ball bearing 012545 for the mainshaft.

Two oilite bushes 042145 are used for footchange spindle. Carefully note their location before driving out. An "O" ring 040006 is used between the outer bush and the cover, which should be discarded before fitting new bushes.

**Removing sleeve gear bushes.** Support the gear in a vice (note the location of the two bushes), then drift out.

**Refitting the bearings.** The oilite bushes in the outer cover are made to size and do not require reaming.

Ream the layshaft bush in gear box .6260" to .6255".

**Refitting sleeve gear bushes.** These two bushes are thin and somewhat brittle. Oil the outside diameter of each bush, insert them squarely in the gear and gently press into position.

Ream both bushes .689" to .688" in situ.

**Refitting the sleeve gear sprocket.** The flat side of the sprocket should face outwards (away from the gear box) see instructions on removing sprocket nut.

**Refitting the oil seal.** The metal backing faces outwards. Gently and squarely tap the oil seal into position.

**Assembling the gear box internals.** The assembly sequence of the various

pinions is clearly illustrated. Ensure the plunger and springs are in position in the gear box shell.

For clarity, assemble in the following order:

- (1) Fit footchange spindle and quadrant.
- (2) Take up the main shaft fit first, second and third gear, enter shaft through sleeve gear.
- (3) Fit mainshaft selector fork and locate it in quadrant.
- (4) Take up layshaft fit second and third gear, enter shaft in bush.
- (5) Fit layshaft selector fork and locate.
- (6) Pass selector fork shaft through both selectors and screw home.
- (7) Fit low gear pinion.

**Precautions during assembly of gear box.**

- (1) Make sure the selector forks 041341/3 are correctly indexed.
- (2) If the end cover does not go back properly, do not use force, take off the cover and find out what is wrong.
- (3) Make sure all gaskets are undamaged, stick them on to the gear box and covers some time before they are refitted.
- (4) Make sure the small peg inside the ball race housing has not fallen out. This locates the clutch operating body.
- (5) Insert the pin 042143 for clutch body from the top end. If this pin is a loose fit, give the top end a few light blows with a hammer to deform it and make it fit tight.
- (6) Put a little clean oil on all moving parts.

**DO NOT OMIT TO FILL THREE PINTS (1.8 LITRES) OF SAE 50 OIL.**

**The kickstarter axle.** Should it be necessary to dismantle the kickstarter, take off the gear box end cover as described elsewhere. The ratchet pinion 041300 is in tension by the ratchet spring 041358. To relieve this tension temporarily, fit the kickstarter crank, and depress it which will release the pinion and enable it to be taken away.

Remove the circlip encircling the shaft, should one be fitted, prise out the end of the return spring 040045, the shaft can now be extracted.

**CSR Models.** The gear box for the CSR model is identical to the standard machines, with the exception of the clutch, which is the same as used on the 350 lightweight. See technical data for gear ratios.

## CLUTCH—LIGHTWEIGHT

To dismantle the clutch, remove outer portion of front chain case (see *ENGINE SERVICE*).

Remove the three clutch spring adjusters, take out the springs and cups.

Take out the clutch plates, noting the order in which they are removed.

Remove the clutch body from the mainshaft. Use a box spanner  $\frac{23}{32}$ " across the flats. Engage top gear, use the tool to stop the clutch from rotating whilst the nut is unscrewed as shown in Fig. 8. Alternatively press hard on the rear brake lever to hold the clutch stationary.

Usually the clutch will come off the shaft splines without the use of an extractor tool.

Friction material is bonded to the plate. When new the segments protrude  $\frac{2}{64}$ ".

Check the steel plates. If they are not flat, the clutch will slip. Put all

the steel plates together, hold them up to the light when it will be seen if one or more of the plates are buckled. Later type plates are "dimpled" to prevent buckling.

Check the free length of the clutch springs which should be  $1\frac{1}{4}$ " overall length.

**Assembling the clutch.** The sequence of assembly is in the following order:

**250 c.c. model.**

- (1) Thick steel back plate chamfer inwards.
- (2) Plain steel plate.
- (3) Friction plate (double sided).
- (4) Plain steel plate.
- (5) Friction plate (double sided).
- (6) Plain steel plate.
- (7) Friction plate (single sided).

**250 c.c. Scrambler.**

- (1) Thick back plate.
- (2) Plain steel plate.
- (3) Friction plate (double sided).
- (4) Plain steel plate.
- (5) Friction plate (double sided).
- (6) Plain steel plate.
- (7) Friction plate (double sided).
- (8) Plain steel plate.
- (9) Friction plate (single sided).

**350 c.c. model.**

- (1) Thick back plate (recess for back plate inwards).
- (2) Friction plate (double sided).
- (3) Plain steel plate.
- (4) Friction plate (double sided).
- (5) Plain steel plate.
- (6) Friction plate (double sided).
- (7) Plain steel plate.
- (8) Friction plate (double sided).
- (9) Plain steel plate.

**Dismantling the clutch shock absorber.** With the clutch removed, take out the three countersunk screws, prise out the cover plate 043187.

Use an old gear box mainshaft held in a vice and put the clutch body on the shaft. Use the tool shown in Fig. 14 then compress the large rubbers, by leverage, use a pointed spoke to pick out the thin rubbers. The thick ones will come out without difficulty.

Use the same method if the gear box is still in the frame, with top gear engaged and pressure on the brake pedal. Very firmly tighten the plate screws and centre pop between the screw head and the plate.

**Assembling the clutch.** After replacing the rubbers, make sure that the three screws are well tightened, then centre pop the screws for security as these screws are prone to come loose.

**The clutch bearing.** The bearing race plate is shown in Fig. 3 part No. 043196. After removing the clutch, take out the three stud nuts 040356.

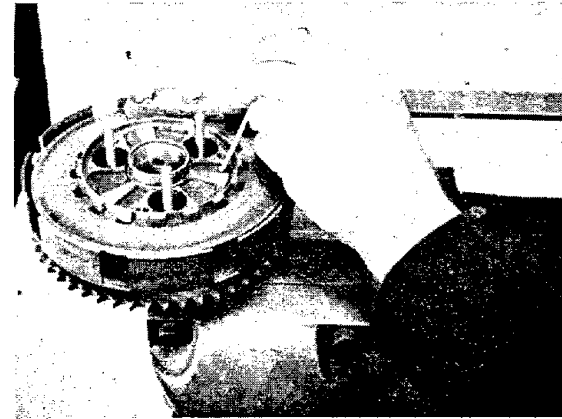

FIG 14 Removing clutch shock absorber rubbers

then the plate 043195, to expose the rollers and cage. Note the closed end of the roller face faces the plate 043195.

**To remove clutch cable.** Remove oil filler cap from kickstarter case cover.

Screw right home the clutch cable adjuster, as far as it will go.

Disengage the cable from the operating lever inside the cover. The cable, after removal from the handlebar lever, can be pulled through the clips fixing it to the frame.

**Clutch spring adjustment.** Should clutch slip develop, first make sure the operating mechanism is in correct adjustment (see clutch adjustment). The correct position for the clutch spring adjuster nuts is—the spring stud should just protrude through the recess in the adjuster nut.

**Clutch adjustment.** Attention to the clutch is usually confined to adjustment of the operating mechanism. To avoid clutch slip or drag, it is essential to have  $\frac{1}{16}$ " free movement between the clutch outer casing and the clutch cable adjuster. Without such movement the operating mechanism will be pre-loaded causing wear on the operating parts, also clutch slip. Conversely, excessive movement in the clutch cable will prevent separation of the friction plates and cause the clutch to drag, thus making the gear selection difficult.

As the clutch inserts tend to settle down, this has the effect of lengthening the clutch push rod, as the width of the friction inserts are slightly reduced. To deal with clutch drag, or clutch slip, first unscrew the clutch cable adjuster lock nut which is located at the handlebar end, run down the adjuster as far as it will go. Remove the clutch inspection cap, unscrew one or two turns the adjuster lock nut 040376, shown in Fig. 3.

With a screwdriver, screw in the adjuster until contact with the push

rod can be felt, unscrew the adjuster exactly half a turn and retighten the lock nut, taking care the adjuster does not move. Complete the adjustment by unscrewing the clutch cable adjuster until there is  $\frac{3}{16}$ " movement between the outer casing and the adjuster, tighten the lock nut. Replace the inspection cap.

Clutch slip should be dealt with promptly otherwise the friction plates will be damaged and the clutch springs affected by heat. The normal free length of the clutch springs is  $1\frac{3}{4}$ ", the clutch push rod length is 10".

#### LIGHTWEIGHT GEARBOX MAINSHAFTS

**350 c.c. Lightweight.** Mainshaft 041701 was fitted to gear boxes with numbers from zero to 3757.

An improved type mainshaft 041703 was first used in gear boxes 3758 and onwards.

**250 c.c. Lightweight.** Mainshaft 041263 is used on gear boxes from zero to 9974, also to gear boxes between numbers 10064 to 10128 as a temporary measure.

A modified shaft type 043058 is used in gear boxes with numbers 9975 to 10063 inclusive, which is now the current type.

The dimensions affecting the various mainshafts are given in Figs. 15 and 16, the drawings are to scale.

**NOTE**—The shaft dimensions affect the vaned shock absorber centre. For mainshafts 041263/041701 use shock absorber centre 043186. For mainshafts 043058/041703 use shock absorber centre 043509.

#### THE GEAR BOX Heavyweight Models

**Gear box faults.** If difficulty in changing gear from top to third and where it has been ascertained that the clutch is not dragging, the fault can be rectified by attention to the gear change stop plate (55). Take out the plate bolts (73), disconnect the pawl spring. Draw out the two plate holes by elongation to the extent of  $\frac{1}{32}$ " to enable the plate to go upwards towards the top of the case. The plate must be retained in this position whilst retightening the two bolts. Should the fault occur when changing into a higher gear, elongate the holes in the opposite direction to the same amount, so that the plate can be moved downwards.

To summarise, if the fault is in changing *down* move the plate *upwards*, conversely if the fault is when changing *up*, move the plate *down*.

If gear selection is generally uncertain, first verify the location of the pawl spring (88). If this spring is distorted or fitted upside down, gear selection will be uncertain. The correct position is with the straight leg of the spring uppermost.

**Oil leaks from kickstarter axle.** Check oil content by removing level plug (87), normal content one pint, or 20 fluid ozs., if normal. Renew the 'O' ring (69) see details 'removing bushes'.

**Wear on kickstarter pawl (41).** Usually due to a weak kickstarter return spring, causing the crank to depress by inertia over bumpy road surfaces. If the crank is too far away from the vertical position the inertia will increase.

Position the crank approximately 20° left of the vertical position.

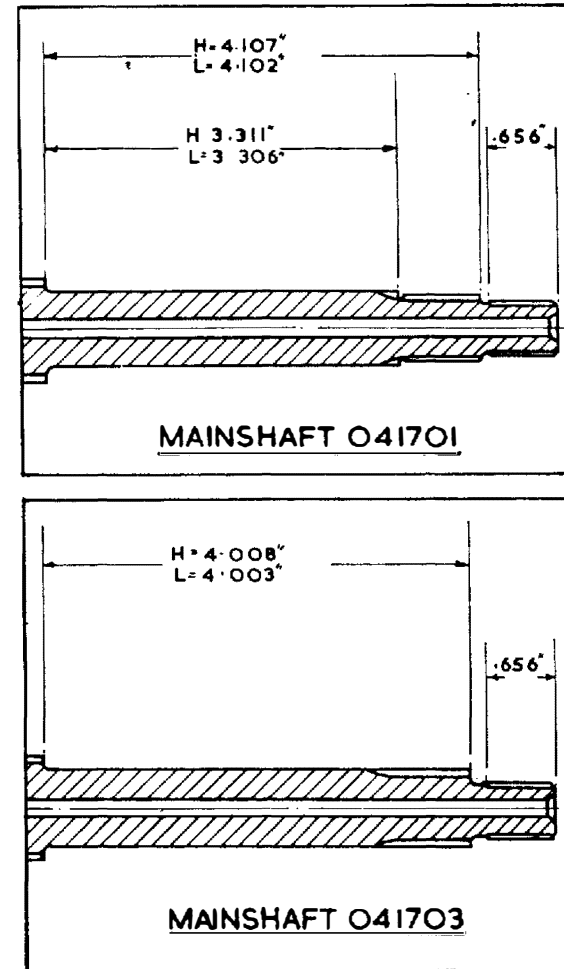

FIG 15

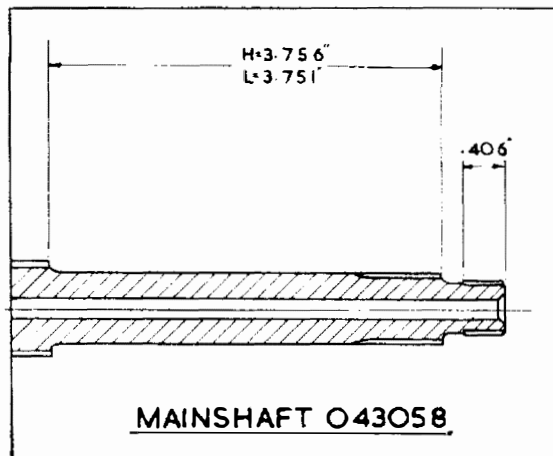
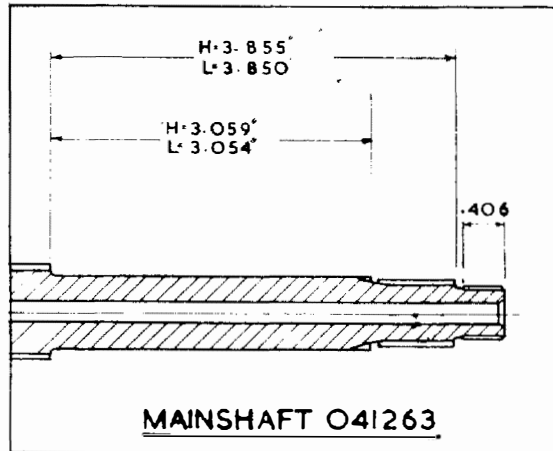

FIG 16

**Damaged kickstarter stop plate (94).** Can only be due to violent backfire causing excessive ignition advance, or too much throttle when starting. Drill the rivet head to remove swaging and push out the pin.

**Kickstarter spring disengages.** This is due to the end of the spring taking 'a set' where it is located in the cover. Usually it is preferable to fit a new spring.

**Gear box noises.** First check oil content. After considerable mileage check layshaft bearing for wear, also layshaft fixed gear pinion (36).

**Removing the kickstarter axle (45).** Lever out the kickstarter return spring from its anchorage in the cover, the opposite end of the spring will come out easily, then pull out the axle.

**To replace kickstarter assembly.** Fit kickstarter axle, with pawl assembled in cover, turn the axle so that the hole in it for the return spring is at 12 o'clock.

Fit return spring on the axle, insert the end of the spring, which is turned down vertically into the hole drilled in axle. Using tool recommended for spring removal, hooked in opposite end of spring, pull the spring sufficiently to enable the turned in end to enter hole drilled in the cover.

Replace inner and outer cover as detailed previously.

**Dismantling the gear box.** (Figures in parenthesis apply to Fig. 17.) If the gear box is to be completely dismantled, first remove the clutch as detailed for 'removing engine from frame', including the rear portion of the front chain case. Have available a new set of gaskets.

**Removing the outer cover (56).** Remove drain plug (15), catch oil as it drains.

Remove inspection cap (66) and disconnect clutch cable inner wire.

Remove bolt for indicator (62) leave pedal in position.

Remove kickstarter crank bolt (90) and take off the crank.

Remove five cheese-headed screws securing cover (68).

Remove cover by pulling on the gear change pedal.

**Removing the inner cover (47).** Remove ratchet plate and spindle (5).

Remove clutch operating arm and roller (82).

Remove lock ring (80), take away the body and ball.

Remove mainshaft nut (74).

Remove seven nuts (89) securing the cover.

Remove cover by tapping the rear portion until it is clear of the dowels.

**Removing gear box internals. Remove low gear on mainshaft (39).**

Remove striker fork (25) by unscrewing.

Remove striker forks (33 and 34).

Remove clutch push rod.

Remove mainshaft (11) with the gears on it.

Remove layshaft and gears; it may be necessary to rock the shaft sideways to extract from bearing.

**Removing the cam plate (26).** Remove the dome nut (20) and take out the spring and plunger.

Remove two bolts (28 and 29) over the plunger housing.

Remove the cam plate and quadrant.

**Removing the sleeve gear (23).** Remove screw fixing lock plate (4).



FIG 17  
Heavyweight gearbox

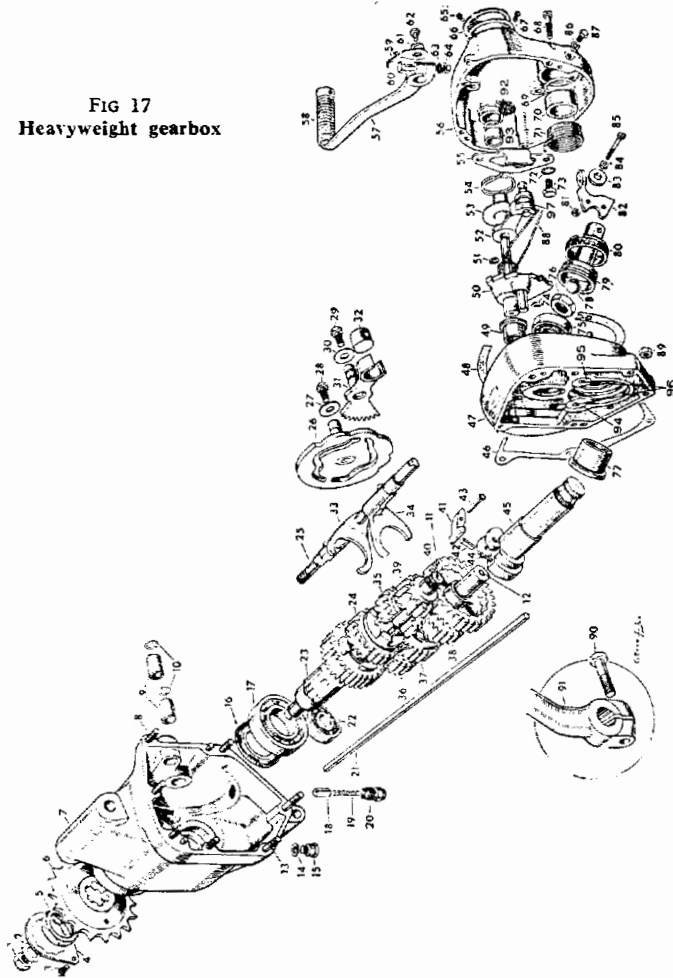

Key to FIG 17

- |                          |                                |                             |
|--------------------------|--------------------------------|-----------------------------|
| 1 Clutch retaining nut   | 37 Layshaft third gear pinion  | 69 Kickstart 'O' ring       |
| 2 Washer                 | 38 Layshaft second-gear pinion | 70 Bush                     |
| 3 Locking screw          | 39 Mainshaft first-gear pinion | 71 Return spring            |
| 4 Locking plate          | 40 Layshaft first-gear pinion  | 72 Stop-plate washer        |
| 5 Locking nut            | 41 Kickstarter pawl            | 73 Stop-plate screw         |
| 6 Drive sprocket         | 42 Plunger                     | 74 Circlip                  |
| 7 Gearbox shell          | 43 Pin                         | 75 Mainshaft ball race      |
| 8 Stud (short)           | 44 Spring                      | 76 Mainshaft nut            |
| 9 Bush                   | 45 Axle                        | 77 Kickstart-axle bush      |
| 10 'O' ring              | 46 Gasket                      | 78 Clutch operating ball    |
| 11 Mainshaft             | 47 Inner cover                 | 79 Clutch operating body    |
| 12 Layshaft              | 48 Gasket                      | 80 Lockring                 |
| 13 Stud (long)           | 49 Gear-change spindle bush    | 81 Clutch-roller nut        |
| 14 Washer                | 50 Ratchet plate and spindle   | 82 Operating lever          |
| 15 Drain plug            | 51 'O' ring                    | 83 Roller                   |
| 16 Sleeve-gear oil seal  | 52 Pawl carrier                | 84 Sleeve                   |
| 17 Main gear ball race   | 53 Washer                      | 85 2B.A. screw              |
| 18 Index plunger         | 54 Return spring               | 86 Oil level-plug washer    |
| 19 Spring                | 55 Stop plate                  | 87 Oil-level plug           |
| 20 Domed nut             | 56 Outed cover                 | 88 Foot-change-pawl spring  |
| 21 Clutch push rod       | 57 Foot-change lever           | 89 Nut                      |
| 22 Layshaft ball race    | 58 Rubber                      | 90 Kickstart bolt           |
| 23 Main gear             | 59 Indicator                   | 91 Kickstart crank          |
| 24 Mainshaft third gear  | 60 Foot-change lever bolt      | 92 Pawl carrier 'O' ring    |
| 25 Selector-fork shaft   | 61 Indicator washer            | 93 Pawl carrier bush        |
| 26 Cam plate             | 62 Indicator fixing bolt       | 94 Kickstart axle stop      |
| 27 Washer                | 63 Foot-change lever washer    | 95 Kickstart axle cam       |
| 28 Bolt                  | 64 Nut                         | 96 Kickstart axle cam rivet |
| 29 Bolt                  | 65 Inspection-cover screw      | 97 Footchange pawl          |
| 30 Washer                | 66 Inspection cover            |                             |
| 31 Quadrant              | 67 Gasket                      |                             |
| 32 Roller                | 68 Outer-cover screw           |                             |
| 33 Selector fork         |                                |                             |
| 34 Selector fork         |                                |                             |
| 35 Mainshaft second gear |                                |                             |
| 36 Layshaft small pinion |                                |                             |

Remove sleeve gear sprocket nut (5), which has a *left-hand* thread. Use a good fitting ring spanner across the flats and refer to method of removing this type of sprocket nut described for Lightweight gear box.

Remove sleeve gear sprocket which is splined; also distance piece.

Remove sleeve gear by tapping it through the bearing (17).

**Removing sleeve gear bushes.** Two thin bushes of the oilite type are used as a bearing for the mainshaft.

Note the location of these bushes *in situ*, before they are pressed out. As the material is somewhat brittle, exercise extreme care in pressing in the new bushes.

The internal diameter of both bushes *in situ* is .81325" to .81200".

**Removing sleeve gear bearing (17).** Remove by prising out the oil seal (16) and sleeve for seal.

Remove bearing after first heating shell and drift out.

Alternatively drop the shell face downwards on a clean bench, when this bearing, also the layshaft bearing (22), will drop out.

**Removing the bearings.** Pre-heat the inner cover and press out from inside the case the mainshaft bearing (77).

If desired the kickstarter axle bush can be extracted at the same time. To do this, firmly support the inside face of the cover and press out the bush from *outside* the cover.

**Removing the footchange spindle bush (99).** This is fitted into a blind aperture. Pre-heat the case and screw in a coarse threaded tap to extract. Use the same method to remove the bush in the kickstarter axle.

**NOTE**—The footchange bush does not require reaming when renewed. If the kickstarter axle bush 040146 is renewed, ream to .6875" to .6865" *in situ*.

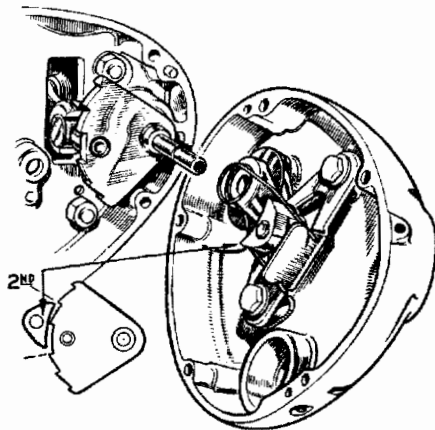

FIG 18

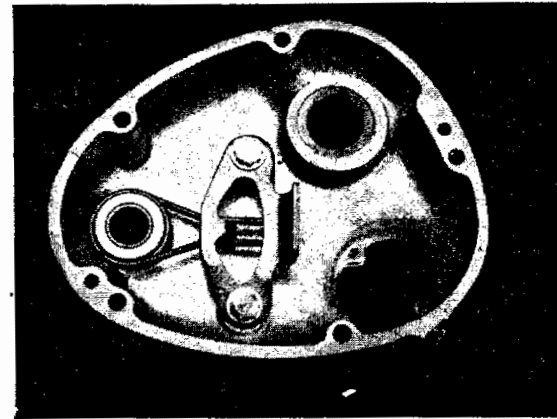

FIG 19

**Re-assembling the gear box.** **NOTE**—Apply some clean oil to all moving parts before fitting.

Fit the sleeve gear ball race (17) and layshaft bearing (22), pre-heat the shell and ensure bearings are entered squarely; apply a little clean oil.

Fit sleeve gear through bearing, and oil the sleeve or distance piece for oil seal.

Fit sleeve gear sprocket and firmly tighten left-hand sprocket nut.

Fit lock plate and screw.

**Refitting the cam plate (26).** The cam plate must be correctly positioned on assembly, otherwise the four gears will not be indexed properly.

(1) Fit the quadrant (31) also its bolt and washer.

(2) Raise the lever portion of the quadrant, with the radius of the lever in line with the top right hand cover stud (top gear).

(3) Insert the cam plate so that the first two teeth of the quadrant can be seen through the slot in the cam plate, then fit the bolt and washer (27).

**Fitting the internals:**

(1) Insert the mainshaft and fit to it the third gear (24).

(2) Fit the second gear (35) with the striker fork (33) in the pinion groove, then insert the projection of the striker into the groove in the cam plate.

(3) Fit the first gear (39).

Assemble the layshaft by:

(4) Fitting the fixed gear (36), third gear (37) and second gear (38) with the striker fork (34) in the slot for second gear.

(5) Insert the projection of striker fork into cam plate slot, with layshaft in the bush.

(6) Line up the two holes in the striker forks and pass through the

spindle (25) and firmly tighten.

(7) Fit the first gear (40).

**To complete the assembly.** Insert the roller (32) into the quadrant in position to receive the spindle for the footchange. Examine the gasket (46) for blemish, locate it and refit the inner cover. Before finally tightening the clutch body lock ring (80) verify the operating lever (82) is in line with the clutch cable entry, to ensure a straight pull on the inner wire. Do not use force, if the cover does not go home easily, take it off and find out why. Check the position of the pawl spring (88) and refit the outer cover. Refill one pint of SAE 50 oil.

**Replacing the footchange pedal spring.** With the outer cover removed, take out the quadrant (50) and the pawl spring behind it. Tap out the footchange sleeve (52) and its washer (53). Remove two bolts (73) and lift away the plate.

The position of the pedal spring assembled is shown in fig. 19.

### CLUTCH—HEAVYWEIGHT

Three types of clutches have been used since 1957. The original design had loose friction inserts in the clutch sprocket, also in the friction plates. This type of clutch was used on all Heavyweight Models up to 1959, with the exception of the CSR Models, which were equipped with the bonded type clutch.

All 1960-61 Models use bonded type clutches.

For the 1962 season a heavy duty five-plate type clutch was introduced for 650 c.c. CSR Models, which can be used on any earlier model.

The early type clutch can be converted by using the following components:

- 1 Back plate 040584.
- 1 Clutch sprocket 040359.
- 4 Steel plates, plain 043191.
- 4 Friction plates 043192.
- 1 Friction plate 043193.

**Clutch slip.** To enable the clutch to function satisfactorily it is essential to have clearance between the clutch push rod and the thrust stud. The fact that there is play, or lost motion, at the handlebar lever end does not guarantee there is clearance between the push rod and thrust stud.

To obtain the correct adjustment run down, as far as possible, the clutch cable adjuster. Remove the chain case cap for the clutch. Release the nut using a screwdriver, screw in the thrust stud until it just touches the clutch push rod.

Unscrew the thrust stud half a turn then retighten the lock nut with care to avoid the stud moving during this process. Now reset the cable adjustment by unscrewing the adjuster, leaving  $\frac{1}{8}$ " to  $\frac{3}{16}$ " free movement between the outer cable and the adjuster.

If the fault prevails, take down the clutch and check the steel plates for buckle. Put all these plates together and hold up to the light, which will indicate if one or more of the plates are buckled, which reduces the friction area.

New type steel plates are 'dimpled' to prevent buckling.

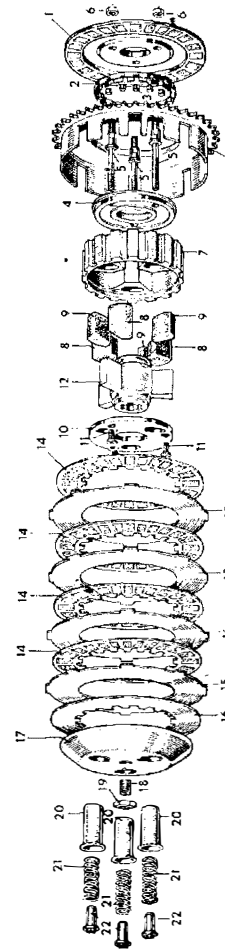

- 1 Back plate (bonded)
- 2 Roller cage
- 3 Rollers (15)
- 4 Race plate
- 5 Spring studs
- 6 Spring-stud nuts
- 7 Centre hub
- 8 Shock rubbers (large)
- 9 Shock rubbers (small)
- 10 Shock plate
- 11 Shock-plate screws
- 12 Shock centre
- 13 Sprocket
- 14 Friction plates (double)
- 15 Steel plates
- 16 Friction plate (single)
- 17 Pressure plate
- 18 Pressure-plate adjuster
- 19 Pressure-plate-adjuster nut
- 20 Spring cups
- 21 Springs
- 22 Spring adjusting nuts

FIG 20  
Clutch components

Replace buckled plates with the new type.

An excess of oil in the front chaincase will adversely affect the clutch. Friction plates so affected should be de-greased as they are usually serviceable. Avoid the use of petrol or paraffin and use trichloroethylene. Alternatively, copiously dust the inserts with Fullers Earth to absorb the oil.

Check also the clutch spring cups, which may be fouling the holes in the alloy pressure plate, preventing the spring from exerting maximum pressure. Apply a little grease to the cups before refitting.

**Clutch springs.** If the clutch has been slipping for any length of time, the heat generated is calculated to weaken the springs, which should be renewed. The correct free length is  $1\frac{25}{32}$ ". The five plate clutch spring free length is  $1\frac{11}{16}$ ". Discard springs which have collapsed to the extent of  $\frac{3}{16}$ ".

**Clutch spring adjusting screws.** If there is a tendency for the springs adjusting screws to become unscrewed, take out the spring, lift up the end of the spring with a pen-knife and file the end of the spring to give a square abutment of  $\frac{1}{8}$ " or get rid of the feathered end. The abutment will then come up against the indentation at the back of the adjuster and prevent it unscrewing. The correct location of the adjusting screws is with the head of the spring stud just flush with the face of the adjusting screw.

If the machine is a combination and heavy loads are carried, and the early type clutch is used, convert the clutch to the bonded type as already described.

**Clutch drag.** This is due to torque on the gear box mainshaft and creates noisy gear engagement. The cause is due to the clutch plates not separating when the clutch is operated. The fault may be due to:

- (1) Excessive play in the operating mechanism (see clutch slip).
- (2) Uneven adjustment of the clutch springs.
- (3) The steel plates are buckled.
- (4) The clutch plates are gummy.

In the case of (2), take off the outer portion of chaincase, operate the clutch lever and note if the outside plate is withdrawn parallel with the plate behind it. If the gap between the two plates is uneven, manipulate the spring adjuster until the gap is equal and evenly between the two plates, with a preference for screwing in the adjuster to balance.

In the event of (4), treat the clutch plates as recommended for clutch slip to get rid of the gumminess.

Needless to say, continual use with clutch drag can cause damage to gear box pinions.

**Clutch nut works loose.** If the mainshaft nut securing the clutch to the mainshaft works loose, this is due to damage to the splines in clutch centre for the shock absorber 040354. To remedy, replace the centre and avoid over-tightening the mainshaft nut.

**To remove a clutch control cable.** Remove the oil filler cap from the kickstarter case cover.

Screw right home the clutch cable adjuster that is located in the top of the kickstarter case cover.

Disengage, from the operating lever, the clutch cable inner wire by

operating through the oil filler cap opening.

Completely unscrew the clutch cable adjuster.

Disengage, from the handlebar operating control lever, the clutch inner wire.

Pull cable, by its lower end, till removed from the machine, easing it through the frame cable clips while doing so.

**Dismantling shock absorber.** Three thin and three thick rubbers are housed in the clutch centre and are located by the clutch hub steel plate (Fig. 20). For access, take out the three screws and move the plate to enable a screwdriver to be used to prise out the plate. To take out the rubbers use a "C" spanner to turn the hub and compress the thick rubbers, which will come out easily after the thin ones have been extracted.

**Clutch bearing.** The clutch hub is secured to the steel back plate by three spring studs and locknuts. After separating the back plate from the hub the bearing can be removed. When replacing, apply a little anti-centrifuge grease to the bearing.

## FRONT FORKS

### Heavyweight, 350 c.c. Lightweight and 250 c.c. Scrambler Models

*(The figures in parenthesis refer to Fig. 21)*

**Stiff fork motion.** First try the effect of releasing the two bolts securing the front mudguard to the fork slider (15). If normal movement is restored use washers between the mudguard and the slider to relieve side strain, or remove the guard and spread the sides. Try also releasing the four cap nuts (33) and work the forks violently to line up the inner tube and retighten the nuts.

If the fork motion is unduly stiff, and assuming the fork tubes are not bent by impact, it is possible that the black bushes (9) have swollen and are a tight fit on the tubes.

To rectify, dismantle the forks and ease down the inside diameter of the bush with emery cloth, until it is an easy sliding fit. Oil the fork tube, or use graphite before assembly.

**Fork noise on full deflection.** Check the bottom cover tube (53) for contact with the slider extension (54), the cover tube may be deformed or canted. Remove the cover tube and set the tube face where it abuts against the fork crown (39) so that it is at complete right angles to the axis of the tube. The tube should be concentric with the slider extension. Usually there are score marks on the slider, under these circumstances.

**Rattle in forks.** One of the damper rods (25) may be detached from the top anchorage. A low oil content will have the same effect.

**Fork spring rattle.** Three neoprene rubber sleeves (Nos. 2, 4 and 5) are placed over the fork inner tubes, near the top, bottom and centre of the fork spring. If these sleeves have piled up at the bottom of the spring, the spring can rattle against the fork tube. Reposition or renew the sleeves to rectify. Apply some grease to the fork springs before refitting.

**Lateral fork movement.** If the steering head bearing adjustment is correct and if there is a juddering effect when the front brake is applied, this can

be due to lateral movement caused by wear on the black fork bushes. The movement can be detected also by jacking up the front wheel clear of the ground when, by raising and lowering the front wheel, the movement will show up. Replace the bushes to rectify.

It is rare for the steel bushes to be affected, providing the fork oil content is not contaminated by abrasive. When replacing the bushes make sure the inside of the fork tubes is perfectly clean.

**Indifferent steering.** If the machine is inclined to steer in an elongated figure of eight, this denotes unwanted friction in the steering which can be due to:

- (1) Steering head bearing over tightened.
- (2) There is friction, which cannot be released if a steering damper is used.
- (3) The steering head bearing is unduly loose and the fork stem is rubbing against the inside of the ball race.
- (4) The ball races are pitted, as a result of driving with a loose bearing adjustment (see 'Steering head adjustment').

In the case of (2) take out the bolt securing the steering damper plate to the frame. If the friction is removed, use washer(s) between the plate and the lug on the frame.

**Handlebars oscillate at low road speed.** This trouble is not associated with the front forks, or wheel alignment. If the handlebars oscillate or 'wobble' at low road speeds and stops as the road speed increases, this is due to either one or both tyres not running true with the wheel rim and invariably becomes manifest after the tyres have to be changed. In the main the front tyre is responsible.

**Oil leaks from forks.** First try the effect of tightening the slider extension (7) to compress the oil seal against the bush. If the leakage persists, replace the oil seal (8).

Should the leak take place at the lower end of the fork slider (15) check the damper tube bolt (31) and its washer for security.

**Loose head lamp brackets.** The top fork cover tube (20) with lamp bracket incorporated is compressed between the handlebar lug (41) and the fork crown (39) with a rubber packing ring (18) interposed. If the rubber ring deteriorates or collapses, the tension on the tube will be reduced. Usually the trouble can be rectified without completely dismantling the front forks, by using a fork spring leather washer 021116 for each cover tube as packing.

Release the two nuts (45 and 46).

Tap upwards the handlebar lug (41).

Make a cut across one side of the washer and feed it round the fork tube, between the rubber and the fork crown. A little soapy water will assist the washer to slide over the rubber.

Re-align the head lamp and tighten the two nuts.

**Head lamp beam.** If the lamp beam is out of parallel to the machine, thump the head lamp shell with the heel of the hand in the required direction.

**Bent fork inner tubes (17).** The fork tubes can be straightened providing the set does not exceed 10° out of true.

Support the tube in 'V' blocks and use an Arbour press.

**NOTE**—The fork tubes must be smooth and free from bruises and blemish, particularly in the part where the oil seal operates, otherwise the seal will be damaged beyond further use, with serious oil leakage.

**Fork damper conversion (Scrambler Models).** For the 1962 season an improved type of fork damping was introduced in the Heavyweight forks fitted to Scrambler Models.

Earlier type forks can be converted by:

Dismantling the forks.

Dismantling the damper tubes (34).

Seal off, by welding, the small hole below the slot for the circlip (37).

Drill a  $\frac{1}{8}$ " diameter hole 2" from the top of the damper tube.

Drill a  $\frac{3}{32}$ " diameter hole 3" from the top of the damper tube.

Reduce the overall length of the top cover tube (16) to 1 $\frac{1}{8}$ ".

Reduce the overall length of the slider extension (7) to 3 $\frac{3}{4}$ ".

Use fork springs 016782.

Discard the buffer springs (10).

Fit two gaiters (dust protectors).

Fit four gaiter clips 042775.

If new parts are required, instead of converting use:

2 Bottom cover tubes	028046
2 Slider extensions	028051
2 Damper tubes	028048
2 Main springs	016782
2 Gaiters	020463
4 Gaiter clips	042775

**Removing the front forks.** Remove the two drain plugs (56) in turn and catch oil in a container.

Raise the front wheel with boxes under footrests.

Remove handlebars (use padding on the petrol tank to avoid damage).

Remove head lamp and disconnect speedo drive cable.

Remove front wheel, mudguard and stay.

Remove steering damper plate to frame (if fitted).

Remove rubber grummets from tube bolts (22), also the two bolts. Use spanner 018667.

Remove lock nuts (24) and adaptor to release damper rods (25).

Remove domed nut (45) and adjusting nut (46).

Tap off the handlebar lug (41) using a rawhide mallet, until the lug clears the fork stem (40) and tubes, the forks can then be taken away as a unit. Watch for steering race ball bearings, 56 in number.

**Dismantling the forks.** Hold the fork stem in a vice.

Remove slider extension (7) from the slider (15) by unscrewing from the slider.

Remove slider by giving it a sharp jerk downwards. The oil seal is a close fit in the top of the slider. If there is resistance in separating the slider, apply a little heat to the top part, which will expand and enable the slider to come away with ease, with the damper assembly attached.

Remove two Allen screws (38) then pull out the fork tubes.

**To remove steel bush.** Prise out the circlip (12) and pull off the bush.

FIG 21 Exploded view of Teledraulic Heavyweight forks

- 1 Washer, leather, for fork spring top seating.
- 2 Buffer, rubber, for fork inner tube.
- 3 Spring, main, for front fork.
- 4 Buffer, rubber, for fork inner tube.
- 5 Buffer, rubber, for fork inner tube.
- 6 Washer, leather, for fork spring bottom seating.
- 7 Extension for fork slider.
- 8 Oil seal, for fork inner tube.
- 9 Bush, top, plastic, for inner tube.
- 10 Spring, buffer, for front fork.
- 11 Washer, plain, for fork slider cap securing stud.
- 12 Circlip, locating fork inner tube bottom bush.
- 13 Bush, bottom, steel, for fork inner tube.
- 14 Circlip, locating fork inner tube bottom bush.
- 15 Slider, for fork, with studs (right side).
- 16 Tube, fork cover, bottom.
- 17 Tube, fork, inner.
- 18 Rubber ring for top cover tube housing ring.
- 19 Housing ring, top cover tube.
- 20 Tube, fork cover, top, right, with lamp lug.
- 21 Spigot ring cover tube.
- 22 Bolt, top, for fork inner tube.
- 23 Adaptor.
- 24 Nut, lock, for top end of damper rod.
- 25 Rod, for fork damper.
- 26 Sleeve, plunger, on fork damper rod.
- 27 Pin, stop, for fork damper valve.
- 28 Nut, lock, for damper valve seat.
- 29 Stud, securing cap to fork slider.
- 30 Washer, fibre, for damper tube bolt.
- 31 Bolt, fixing damper tube to slider.
- 32 Cap, for fork slider.
- 33 Nut, for fork slider cap securing stud.
- 34 Tube, for fork damper.
- 35 Seat, for fork damper valve.
- 36 Valve, for fork damper.
- 37 Clip retaining damper rod sleeve.
- 38 Screw, pinch, for fork crown.
- 39 Fork crown, not sold separately.
- 40 Stem, for fork crown, not sold separately.
- 41 Lug, for handlebar and steering head.
- 42 Collar for buffer spring.
- 43 Washer for fork stem adjusting nut.
- 44 Ring, rubber, sealing, for inner tube top bolt.
- 45 Nut, lock, for fork stem.
- 46 Nut, adjusting, for fork stem.
- 47 Clip (half only), for handlebar lug.
- 48 Screw, pinch, for handlebar clip.
- 49 Bolt, top, for fork inner tube.
- 50 Spigot ring top cover tube.
- 51 Tube, fork cover, top, left, with lamp lug.
- 52 Housing ring top cover tube.
- 53 Tube, fork cover, bottom.
- 54 Extension, for fork slider.
- 55 Slider, for fork with studs (left side).
- 56 Screw, plug, with fibre washer, for fork slider oil drain hole.

NOTE—Washer (43) deleted from assembly.

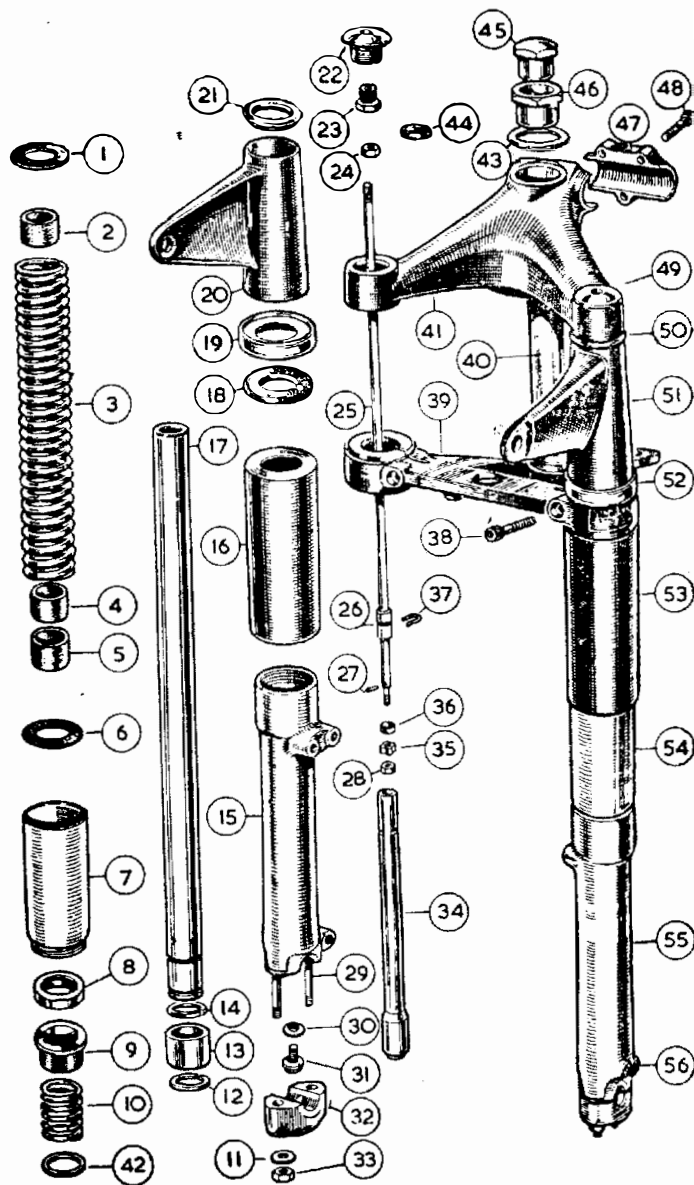

If the circlip becomes distorted during removal, replace it with a new one. **To dismantle the damper tube.** Use a thin wall box key to take out bolt (31) in the slider recess  $\frac{1}{4}$ " across the flats; pull out the damper tube, with damper rod assembled.

Pull out the circlip (37), extract the damper rod with valve assembled. If the valve is taken off the rod, watch for small pin (27).

#### TABLE OF FORK SPRINGS USED

250 c.c. Scrambler Model and Lightweight 350 c.c.		
Part No. 014950	Free length 11"	Wire gauge .207"
350 c.c. Trials Model		
Part No. 014950	Free length 11"	Wire gauge .207"
Heavyweight Scrambler Model		
Part No. 021790 (CSR)	Free length 11 $\frac{1}{4}$ "	Wire gauge .222"
Part No. 016782 1962 (CS)	Free length 12 $\frac{3}{4}$ "	Wire gauge .212"
Heavyweight Touring Model		
Part No. 022369	Free length 11.90"	Wire gauge .212"
Heavyweight Sidecar Model		
Part No. 021789	Free length 12 $\frac{3}{4}$ "	Wire gauge .222"
<b>Buffer springs.</b>		
All Models except 350 c.c. Trials		
Part No. 022079	Free length 2 $\frac{25}{32}$ "	Wire gauge .192"
350 c.c. Trials, 250 c.c. Scrambler and 350 c.c. Lightweight		
Part No. 010360	Free length 2 $\frac{21}{32}$ "	Wire gauge .187"

**To remove one fork tube.** If attention to one fork tube only is necessary, the fork tube and components can be extracted by:

(1) Taking out the front wheel, mudguard and stays.

(2) Remove the domed nut (22), disconnect the damper rod and release the Allen screw (38).

Usually the fork tube is a close fit in the two top members (39 and 41), thus to avoid damage to the internal thread in the fork tube, a draw bolt is required, which is also used to pull back the tube. The tools for the large, also small, diameter fork tubes are shown in Fig. 22.

Insert the tool into the fork tube which can now be driven out.

If at this stage the slider has to be removed, and if the tube is held in a vice, use a suitable clamp and hold the tube at the top and away from the oil seal travel.

**Assembling the forks** (without a draw bolt). Hold the fork crown in a vice.

Assemble a fork tube with its components as described in 'Assembling the forks with a draw bolt'.

Push the fork tube into the fork crown.

Insert the key 018667 in the Allen screw.

With one hand pull up the tube until it protrudes  $6\frac{1}{2}$ " and quickly tighten the Allen screw.

Then assemble the second tube in a similar manner.

Fit the crown races with bearings as previously described and pass the fork stem through the frame.

If assistance is available hold the forks in position, assemble the top

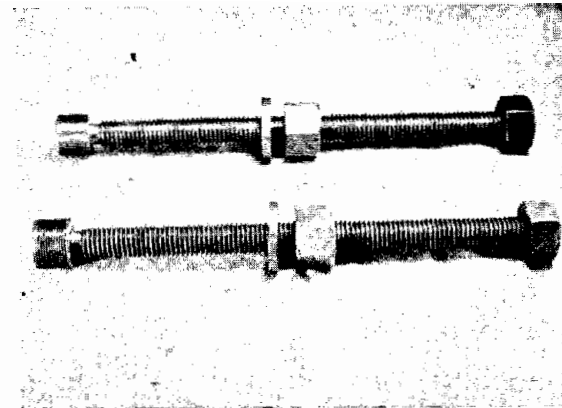

FIG 22 Fork tube tool

frame race and bearings.

Alternatively, place a box under the forks to support.

Assemble the two top cover tubes and handlebar lug, connect the damper rods to the top bolts.

Engage the top bolts as far as possible, then release the clamp screws.

Firmly tighten the top bolts then the clamp screw. (See 'Special precautions').

Adjust the steering head bearings and fill oil to each fork tube.

**Steering head adjustment.** The steering head frame races are of the floating self-aligning type and have spherical seats. Therefore they do not fit tightly in the head lug.

Occasionally test the steering head for correct adjustment by exerting pressure upwards from the extreme ends of the handlebars.

It is particularly important that the adjustment is tested after the first 100 miles because of the initial settling down that always occurs in that period.

Should any shake be apparent, adjust the steering head bearings.

**Adjust steering head bearings by:** Jacking up the front of the machine so that all weight is taken off the front wheel. (A box under each footrest serves that purpose).

Slacken the two fork crown Allen screws.

Slacken the domed nut at top of the steering column.

Screw down the nut underneath the domed nut a little at a time and while doing so, test the head assembly for slackness by placing the fingers over the gap between handlebar lug and frame top lug, at the same time exerting upward pressure by lifting from the front edge of the front mudguard. Tested in this manner the slightest slackness is discernible.

Continue to tighten the lower adjusting nut until no perceptible movement can be felt and yet the steering head is perfectly free to turn, then tighten down the domed nut in order to lock the adjustment.

Securely tighten the two fork crown Allen screws (this is very important).

Remove packing from under footrest.

*Special precautions:* It is vitally important to firmly and positively tighten the two Allen screws (38) which clamp the fork tubes.

Movement between the tubes and the fork crown (39) will cause 'fretting' which can weaken the tube.

Never attempt to repair a fork slider after damage by impact, by welding. Where serious damage has occurred after frontal impact, carefully examine the slider for latent cracks.

**Steering angle.** When the Duplex tube frame was introduced in 1960, a slight alteration to the steering angle was made to improve steering, also road holding. The parts affected are the fork crown and stem and the handlebar lug.

Whilst the difference between the old and new parts is exceedingly small, it does affect interchange of the fork parts individually, viz., whilst both the new type handlebar lug with fork crown can be used on early models as a pair, they cannot be used separately.

As the new parts are virtually identical in appearance, they can be identified by the figure 6 stamped on each part.

**Fitting a sidecar.** To accommodate the extra load the solo fork springs should be exchanged for a stronger type (see 'Table of fork springs'). In the case of a heavy type sidecar, the rear suspension springs must be changed also. Fit a steering damper to offset heavy steering and stop handlebar wobble.

See 'Technical Data' for engine sprocket.

**To re-assemble the forks** (using a draw bolt). Check steering head races for pitting or damage. Pack the lower crown race with grease and fill with 28 steel bearings, put the lower frame race over the stem to retain the bearings. Pack the top frame race with grease, fill with 28 bearings and place it in the frame.

Take up the fork crown and pass it through the frame, fit the handlebar lug and hold these two members together by fitting the nut (46).

Assemble the top cover tubes in the sequence shown in Fig. 21 and fit them between the fork crown and handlebar lug. It may be necessary to release the nut (46) to do this, then retighten this nut to clamp the cover tubes. The steering head adjustment can be dealt with later.

**Assembling the fork tube.** With the fork tube horizontal apply a little oil to the bottom end of the tube.

Fit the oil seal, metal backing towards the top, use a rotary motion at the bottom end of the tube.

Fit the black bush, flange upwards, buffer spring and collar (42).

Fit one circlip, the steel bush and second circlip.

Fit from the top end, slider extension, leather washer (6).

Take up the fork slider, with damper rod assembled, pass it over the fork tube from the bottom end, engage the slider extension.

Fit rubber sleeves, spaced over fork spring length.

Fit main spring, leather washer and top tube (16).

Fit the tube assembled into the two top members, as far as it will go, tighten the clamp screw lightly to hold the tube in position.

Fit the draw bolt, well engaged in the tube and pull the tube home.

Firmly tighten the clamp screw to stop the tube from moving and take away the tool.

Fit damper rod (see 'Changing fork springs') to top bolt and firmly tighten. Fill each tube with 6½ ozs. (186 c.c.) SAE 20 oil.

**Changing the fork springs.** The fork springs can be examined, or exchanged, without entirely dismantling the forks. The draw bolt, as illustrated, is necessary for this operation.

First detach the front brake cable at the handlebar end.

Take out the two fork tube nuts (49), disconnect damper rods.

Release the two Allen screws (38), clamping the fork tubes.

As the front wheel spindle is attached to the forks, it is obvious that the fork tubes are extracted simultaneously. To do so, engage the fork tool in the tube (a fair way down) and drive the tube downwards a small amount.

Transfer the tool to the other fork tube and treat it likewise.

Repeat the operation, transferring the tool from one tube to the other, until they are clear as depicted.

**To reassemble.** Refit the assembly and enter the tubes as far as they will go. The tubes should be parallel with the covers. Run back the large nut on the tool and engage it in one of the tubes. Run down the tool nut and tighten, to pull the tube back a slight amount, thus reversing the method used for extracting the tubes.

An old engine push rod, with the adjuster cup taken out can be used to bring up the damper rods. Alternatively, use a loop of copper wire. Assemble the damper rods to the top anchorage and firmly tighten the lock nuts. Refit the tube top bolts, firmly retighten the two clamping screws.

## 1964-1966 Front Forks

**Lubrication.** Use one of the grades of oil, S.A.E. 20 as shown in the table of lubricants. The normal oil content is five fluid ozs. (142 c.c.). Attention is only necessary at the first 1,000 miles and again at 10,000 miles when the oil should be changed by draining. An exploded drawing of the front forks is shown in Fig. 24 from which it will readily be seen that the fork springs abut against the filler plugs (34), before removing these plugs weight must be taken off the front wheel, by placing the machine on its central stand to avoid the forks collapsing.

**To drain the forks.** With the machine on the central stand: Unscrew the two filler plugs (34). Have available a container to catch oil drained, then remove the drain plug screw (7) with its washer, with the container under the fork leg. If the wheel is inclined to one side, draining will be more complete. Deal with the other fork leg in a similar manner.

**Filling oil.** It will be seen that the air space between the fork spring, and the inside of the tube is very close; therefore fresh oil must be filled with



extreme care, to avoid losses by spilling. Use a measured container for the correct content of 5ozs. Replace the drain plugs before filling, also firmly tighten the filler plugs after.

**Steering head adjustment.** On a new machine the filler plugs (34) should be checked for tightness due to settling down, check as well the steering head bearing at the first 100 miles, and then occasionally, as the mileage increases. Using the machine with movement in these bearings will damage the races. Movement in these bearings can usually be detected when the front brake is applied. To check, raise the front wheel well clear of the ground, with a box under the crankcase. Try to raise or lower the front wheel with one hand and use the fingers of the other hand encircling the handle bar lug where it meets the frame, when movement can be felt. To adjust bearings a thin open ended spanner  $1\frac{1}{8}$ " across the flats is needed. First release the tube clamping stud nut (28), unscrew the stem nut (37) slightly. Use the thin spanner on the sleeve nut (30) and manipulate as necessary. The bearing should be devoid of play with free movement. Retighten the column nut, also the clamping stud nuts.

**Steering lock.** The lock is pressed into the handle bar lug, and can be removed by driving it out from underneath. A number is stamped on the bottom of the lock for key identification.

**Dismantling the forks.** The forks can be removed as a unit, or the fork legs can be removed individually. To take out one fork leg remove the front wheel as described elsewhere. Take off the front mudguard with stays. Release nut for pinch bolt (28). Remove filler cap plug (34), disconnect it from the damper rod, by using two spanners.

The fork inner tube can now be drawn downwards clear of the handlebar lug and fork crown. If the tube resists removal fit back the filler plug without being connected to the damper rod, screw in a few turns, then give it a few sharp blows with a soft faced mallet to separate the tube from its taper fixing in the handlebar lug.

**To remove the forks as a unit.** Follow the instructions given for removing a fork leg, as far as disconnecting the filler plugs from the damper rods. Proceed by taking off the headlamp leaving it suspended by the loom. Separate the control cables from the levers, and remove handlebars. Remove the column nut (37) then give the underside of the handlebar lug one or two blows with a mallet until it is clear of the fork tubes. At this stage support the ends of the forks, for after removing the sleeve nut (30) the forks will drop out. Watch for steel balls for the races, there are 18 in each race (36 in all) if a steering damper is fitted detach the fixed plate from the frame.

**To dismantle a fork slider.** Remove from the fork slider the bolt fixing damper tube (11). Unscrew the bottom cover (23), holes are provided for a C spanner. Take away the fork slider (5).

The damper tube with the fork spring can be extracted from the tube. To dismantle further, take off nut securing fork spring, unscrew the damper tube cap (16) with a tommy bar through the holes in the damper tube, for if this is held in a vice it will distort and become useless. The damper assembly sequence is clearly depicted in Fig. 24.

**NOTE**—When removing the oil seal, sealing washer and flanged bush pass

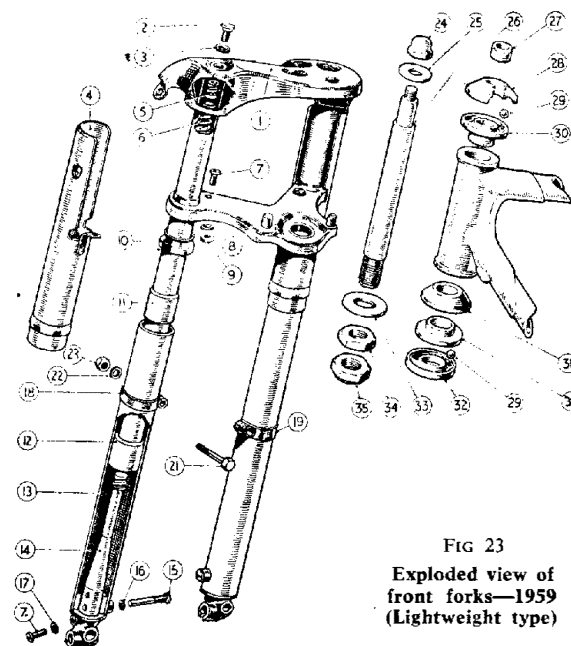

FIG 23  
Exploded view of  
front forks—1959  
(Lightweight type)

- |    |   |    |                                  |
|----|---|----|----------------------------------|
| 1  | Fork, H.                                  | 17 | Drain screw fibre washer.        |
| 2  | Inner tube top screw.                     | 18 | Mudguard clip left.              |
| 3  | Inner tube top screw fibre washer.        | 19 | Mudguard clip right.             |
| 4  | Top cover tube.                           | 21 | Mudguard clip bolt.              |
| 5  | Inner tube top adaptor.                   | 22 | Mudguard clip bolt washer.       |
| 6  | Main spring.                              | 23 | Mudguard clip bolt nut.          |
| 7  | Drain screw.                              | 24 | Nut, domed top.                  |
| 8  | Top cover tube shakeproof washer.         | 25 | Washer top domed nut.            |
| 9  | Top cover tube fixing screw nut.          | 26 | Head stem.                       |
| 10 | Oil seal.                                 | 27 | Spacer for head stem.            |
| 11 | Assembled part.                           | 28 | Adjusting race.                  |
| 12 | Assembled part.                           | 29 | Balls steering.                  |
| 13 | Slider extension.                         | 30 | Frame race top and bottom.       |
| 14 | Damper tube.                              | 31 | Dust cover for ball race.        |
| 15 | Damper tube retaining screw.              | 32 | Crown race.                      |
| 16 | Damper tube retaining screw fibre washer. | 33 | Washer head stem bottom nuts.    |
|    |   | 34 | Head stem adjusting nut, bottom. |
|    |   | 35 | Head stem lock nut, bottom.      |

### 1964-66 Front Fork Assembly

- 1 Fork main tube
- 2 Main tube bush
- 3 Main tube bottom bush
- 4 Main tube bottom bush circlip
- 5 Fork end left hand
- 6 Fork end right hand
- 7 Fork end drain plug
- 8 Washer for plug
- 9 Oil damper tube
- 10 Oil damper rod
- 11 Oil damper tube bolt
- 12 Washer for bolt
- 13 Washer for tube
- 14 Nut for rod top
- 15 Nut for rod bottom
- 16 Damper tube cap
- 17 Piston locating peg
- 18 Oil damper valve cup
- 19 Oil damper valve cup slotted ring
- 20 Main tube lock ring with cup
- 21 Main spring
- 22 Main spring locating bushes
- 23 Spring cover tube
- 24 Spring top cover tube securing plate
- 25 Screws securing plate
- 26 Crown lug complete with column
- 27 Pinch stud for crown lug
- 28 Nut for stud
- 30 Fork head race adjuster nut
- 31 Top cover left hand
- 32 Top cover right hand
- 33 Main tube top cover ring
- 34 Fork main tube filler and retaining plug
- 35 Washer for plug
- 36 Fork head clip
- 37 Fork crown and column lock nut

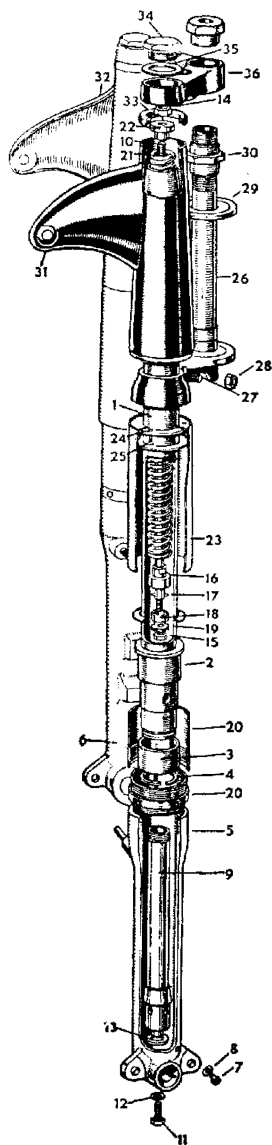

FIG 24

them along the fork tube and take off from the top end past the taper end, if the oil seal is to be used again.

**Assembling the forks.** It will be apparent from the dismantling instructions given that there is nothing complicated in the fork assembly and if the reverse sequence is used, no difficulty should occur with the following precautions.

The fork tube, where the oil seal operates, must have a smooth finish and free from blemish.

The oil seal is fitted from the top of the tube, with the visible spring facing downwards against the flange for the bush.

The damper tube cap also the damper tube fixing bolt must be properly tightened.

Finally tighten the bottom cover (23) when the front wheel has been put back.

Fill 5 ozs. of S.A.E. 20 oil to each fork leg.

### Front Forks 250 c.c. Model

An exploded view of the front forks is shown in Fig. 23.

**Dismantling the forks.** Remove the front wheel as described in 'Wheels and brakes' section.

Take off the head lamp front and detach bulb holders.

Disconnect the speedometer drive cable.

Detach the black and blue cable plugs.

Detach ammeter wires and dip switch cable.

Detach handlebars.

Detach front mudguard by taking out the two clip bolts, expand the clip a trifle to avoid damage to enamel.

Detach drain plugs (7) and catch the oil.

Detach head stem nut (24), watch for three shim washers.

Detach steering head stem and support the forks. Watch for head bearings (29), set of 39 and take away forks. Support the forks in a vice, take out screw (2), and pull off the bottom slider extension (13) with fork spring attached.

Detach two screws securing top cover tube, and take tube away.

Detach bolt (15), pull out fork spring and damper. The spring is screwed on to the damper, also the top spring anchor.

**Removing the oil seal.** The oil seal will come away attached to the slider. Secure the slider in a suitable clamp fixed in a vice.

Bring the mudguard clip up to the oil seal body, using a series of light blows with a hammer directed on to the ears of the clip. Move the clip round the seal body whilst doing this to remove it squarely.

**Re-assembling the front forks.** The work involved is straightforward with the following precautions:

(1) After fitting the cover tubes leave the two fixing screws loose. When the forks are assembled and working correctly, retighten the screws.

(2) Assemble the oil seal to the slider squarely.

(3) When refitting the slider bring the seal up to the bush. Use a small radio-type screwdriver or similar tool, insert the tool between the oil seal rubber and the fork bush. Use a rotary motion pressing gently against the

4 slider, the seal will go over the bush without damage.

Refill with 70 c.c. of S.A.E. 30 oil.

**NOTE**—The fork tube bushes are silver soldered to the tubes  $5\frac{1}{4}$ " apart. **Steering head adjustment.** With the machine on the stand, need for adjustment of the steering head bearings may be detected by trying to rock the forks with hands holding the fork legs. The bearings should be tested for slackness after the first 200 miles and subsequently every 1,000 miles. Two spanners should be used, one turning the adjusting nut (34), the other to slacken and retighten the lock nut when the adjustment has been carried out.

Adjustment should be such that no play be felt, yet the bearings are free to rotate and are not over tight.

Adjusting the bearings too tightly will ruin them and induce heavy steering.

**NOTE**—It is important that adjusting and locking nuts are tightly locked together.

**Front Forks 350 c.c. Lightweight Model, CSR, also  
250 c.c. Scrambler**

The front forks fitted to these Models are virtually identical in design to those fitted to the Heavyweight Models. The difference is confined to the diameter of the fork inner tubes. Therefore, the assembly and maintenance details given for the Heavyweight Models apply also to the Lightweight counterpart.

**REAR SUSPENSION UNITS**

These are sealed units. Maintenance is confined to greasing the outside diameter of the springs should a grating noise develop during movement. The damper fluid filled is sufficient to outlast the life of the unit. Should an oil leak develop, the damper unit must be exchanged.

**Removing the units.** Simply take out the top and bottom fixing bolts, the unit will come away.

**Removing the top cover tube.** To do this the spring is compressed to extract the split collets. Without the aid of a spring compressor tool, the collets can be removed with the unit attached to the frame. The assistance of a second person is required to press down the cover tube (compressing the spring) and smartly prise out the collets. It may be necessary to deal with one collet at a time. Alternatively, hold the top end of the unit in a vice and use the first method.

**Removing the rubber bushes.** These are a press fit and can be extracted without difficulty. To refit use a little water on the rubber, which will facilitate entry without deterioration of the rubber.

**The cam ring adjuster.** By applying less than half a turn to the stepped cam (use spanner 023284) the suspension is corrected and retained to suit the change of load. This also enables the head lamp beam to remain unaltered.

**TABLE OF REAR SUSPENSION SPRINGS**

Model	Part Free		Colour marking
	No.	length	
250 c.c. Scrambler ...	043178	8 $\frac{1}{4}$ "	Green/Yellow/Green

350 c.c. Trials Model ...	043312	8 $\frac{1}{4}$ "	Red/Red/Red
Heavyweight Scrambler	024443	8 $\frac{1}{4}$ "	Green/Green/Green
" Touring Model ...	023373	8 $\frac{1}{4}$ "	Red/Pink/Red
" Sidecar Model ...	023372	8 $\frac{1}{4}$ "	Blue/Yellow/Blue
250 c.c. Touring Model, CSR	043312	8 $\frac{1}{4}$ "	Red/Red/Red
350 c.c. Lightweight Model	043179	7 $\frac{1}{4}$ "	Green/Blue/Green

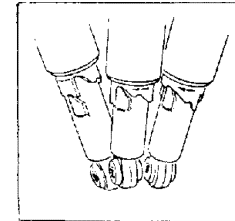
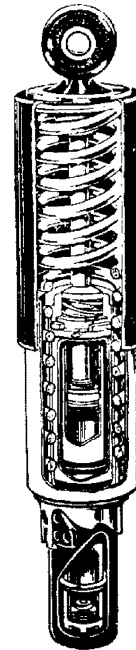

FIG 25 Rear suspension unit

**THE FRAME**

**Lightweight Models.** Details for removing the engine and gear box, the forks and wheels, have been described elsewhere. The further dismantling of the frame is self-evident.

**The swinging arm.** If movement develops between the swinging arm and the main frame, this does not necessarily indicate that the two spindle bushes are worn.

<sup>4</sup> First try the effect of releasing the nut fixing the cotter pin on the left side of the arm. Tap the cotter pin upwards, then knock together the two tubular members and drive back the cotter pin and retighten. This will absorb end play, which is often associated with wear in the bushes.

**To remove the bushes.** Both bushes are a press fit in the frame. They can be removed by using a tubular drift passed through one of the bushes. The finished size of the bush *in situ* is  $\frac{1}{4}'' + .0075'' - .005''$ . Pack the spindle orifice with graphite grease before fitting swinging arm.

**The accessory compartment.** The ignition coil and electric horn are exposed after removing the accessory cover on the left side of the machine, by unscrewing the knurled knob then taking out the two  $\frac{1}{4}''$  diameter bolts and nuts at the bottom of the compartment.

**Tool box compartment.** Fitted to the right side of the machine. Remove the knurled knob, the tools are located in a second compartment, the lid is secured, also by a knurled knob. To remove the compartment, take out two  $\frac{7}{8}''$  bolts and nuts which are visible when the lid is opened.

**The central stand.** The central stand pivots on the footrest rod. To remove the stand, take the footrest arms and with no load on the stand, drive out the footrest rod. There is a distance piece together with a stop plate each side of the engine support channel.

**The stand spring.** Usually trouble free. The spring is anchored between the operating rod and a spacer. The spacer is secured by a recess in the channel. Spring the channel apart, the spacer will fall out.

**The stand stop.** Is fitted between the right side pillion footrest arm and the frame channel.

A rubber grummet, which is detachable, goes through the bracket to prevent metallic contact.

**Frame strip down (Heavyweight Model).** Strip down as detailed for removing the engine and gear box.

Take out both wheels, also take off the head lamp and loom by:

Disconnecting the battery wires and removing the twin seat.

Disconnecting horn, coil and rectifier cables (if alternator model).

Disconnecting control box cables (if fitted) and take it out of the tool box.

Disconnecting stop light switch and rear lamp wires.

Release screw on head lamp rim and take it away with reflector assembly. Disconnect main and pilot bulb wires; also speedo lamp wire. Place the reflector in a safe place.

Disconnect speedo drive cable, pass the cable through the head lamp and fork crown.

Remove dipper switch with cables.

Remove head lamp bolts, release clips on frame, take the head lamp away with the loom.

Remove the front forks as described in 'Fork' section.

Remove frame cover, secured by two slotted screws.

Remove oil tank by taking out the top front fixing bolt.

Remove air cleaner (two bolts).

Remove tool box attached to rear frame loop by two  $\frac{1}{4}''$  bolts.

Remove both rear suspension units.

**Removing the rear mudguard.** Remove  $\frac{1}{4}''$  bolt securing rear guard to frame loop.

Remove  $\frac{3}{8}''$  stud fixing bottom front of the guard to the frame lug.

Remove bolt (3) and spacer, and chain guard.

Remove bolt fixing rear chain guard at front.

**To remove the rear loop.** Remove stud uniting rear loop to seat lug.

Remove nut for stud on right side of rear loop.

Remove this stud with brake pedal attached, take away the rear loop.

Remove screw for plate in swinging arm.

Release the two cotter pin nuts which locate the bearing tube. Push out the bearing tube.

**Swinging arm bushes.** The two flanged bushes are housed in steel sleeves which are not supplied separately. The bushes are of the oilite type, but provision is made for lubrication via the centre plate screw (use heavy duty oil). If lateral movement develops at the wheel end this could be due to end float between the arm and the frame lug, particularly after long mileage, with a sidecar attached.

**Taking up side play.** When it has been ascertained that end play is manifest, it is extremely difficult to absorb this movement by moving the bushes with the arm assembled in the frame, even with a sturdy support on one side of the arm. Whilst the bush in the opposite end is drifted in, there is always a certain amount of spring in the two extremities of the arm. It is therefore preferable to take the swinging arm away from the frame.

To decide if the bearing tube or the bushes are worn, the spindle diameter is .9995"/.9990", the bush diameter *in situ* is 1.001". At the factory a pilot reamer 1" diameter is used for these two bushes, for correct alignment.

## WHEEL BEARINGS Heavyweight Models

The break down of the front wheel bearings is shown in Fig. 26. It is vitally important to avoid tightly adjusting bearings of the taper roller type, as a crushing action takes place, the rollers will be damaged beyond further use. Should excessive movement suddenly develop, the bearing should be dismantled for inspection, for with correct adjustment and constant lubrication, these bearings will last indefinitely.

**To dismantle the bearing.** Remove the front wheel.

Remove nut securing brake cover plate (12).

Remove locating nut (11) and washer.

Remove locking ring (10) and cover disc.

Remove adjusting ring (9).

Press out the spindle from the threaded end which will push out items 6-7-8 and bearing ring 5.

The bearing ring will remain in the left side of the hub.

**To extract the bearing ring.** Press in the washer (4) sufficiently far enough to permit the circlip (1) to be extracted.

Use a piece of steel tubing passed through the hub and drift out the bearing sleeve, which will also eject the washer (4), oil seal (3) and collar (2).

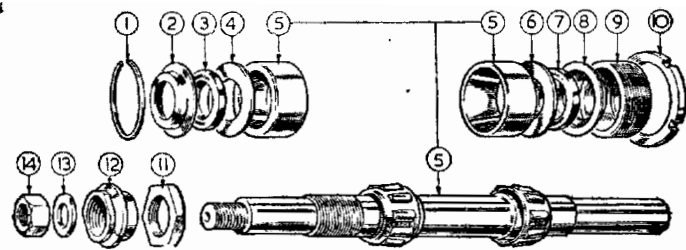

FIG 26 Front wheel bearings

- |                          |                                  |
|--------------------------|----------------------------------|
| 1 Circlip                | 8 Oil seal cup                   |
| 2 Oil seal cup           | 9 Adjusting ring                 |
| 3 Oil seal               | 10 Adjusting ring locknut        |
| 4 Washer retaining seal  | 11 Nut locating brake coverplate |
| 5 Wheel spindle complete | 12 Nut securing brake coverplate |
| 6 Washer retaining seal  | 13 Spindle end washer            |
| 7 Oil seal               | 14 Spindle end nut               |

Avoid using heavy hammer blows when taking the spindle out, as this action can cause indentations in the bearing sleeve.

**Adjusting the front wheel bearing.** Release the locking ring (10), screw in the adjusting ring (9) until the bearing is devoid of end movement, unscrew the adjusting ring half a turn only, give the opposite end of the spindle a light blow to move the bearing ring away from the bearing.

Position the cover disc and firmly retighten the lock ring.

There should be approximately .002" side rock at the wheel rim if the adjustment is correct. The friction of the oil seals can create a false impression that the bearing is tight.

**Dismantling rear wheel bearing (Fig. 28).** Before removing the rear wheel, release the speedo drive fixing nut (16), disconnect speedo cable and take out the wheel.

Remove the nut (16) and speedo gear box, release the lock ring (13).

Remove adjuster sleeve (14) and speedo gear box sleeve (2), and cover disc.

Remove the washer (3), oil seal (4) and oil seal cup (5); also distance piece (6).

Turn to the brake side of the hub, when with the use of a short steel rod or tubing, with an external diameter of  $\frac{1}{4}$ " drift out the hub internals, leaving the bearing ring (7) *in situ*.

**To remove the bearing ring.** Press inwards the steel cup washers (5) to permit extraction of the circlip (11), take out the cup washer, oil seal and spacer (6). Drift out the bearing ring with a length of steel tubing.

**NOTE**—When refitting the circlip press back the bearing ring. See 'Wheel bearing adjustment'.

**Brake drum bearing Fig. 28.** With the brake drum away from the frame, to dismantle:

- Remove dummy spindle (12).
  - Remove circlip (11) and cup for oil seal (5).
  - Remove bearing by drifting out, with second cup.
  - Remove oil seal (4) and distance piece (6).
  - Refit the oil seal with metal backing towards the inside of brake drum.
- Use a little anti-centrifuge grease for the bearing.

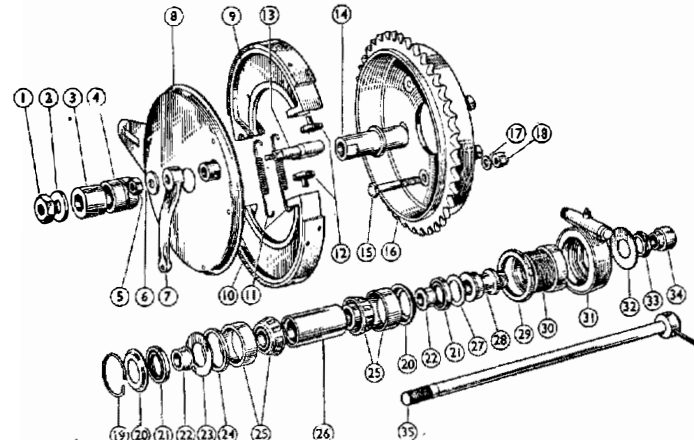

FIG 27 Non-quick-detachable wheel assembly

- |   |   |
|---|---|
| 1 Nut for wheel solid spindle             | 21 Oil seal, for bearing                        |
| 2 Washer, for wheel spindle nut           | 22 Spacer, on spindle, for oil seal             |
| 3 Spacer, for wheel spindle nut           | 23 Ring, retaining hub bearing, large           |
| 4 Spacer, for cover plate, outer          | 24 Spacer, between bearing and oil seal         |
| 5 Nut, for expander lever                 | 25 Bearing, roller                              |
| 6 Washer, for expander lever nut          | 26 Spacer, between bearings                     |
| 7 Lever, expander                         | 27 Ring, retaining hub bearing, small           |
| 8 Plate, cover                            | 28 Spacer, on spindle, for speedometer gearbox  |
| 9 Shoes, brake, with linings              | 29 Nut, lock, bearing adjusting ring            |
| 10 Linings, for brake shoes               | 30 Ring, adjusting bearing                      |
| 11 Spring, for brake shoes                | 31 Speedometer gearbox                          |
| 12 Pin thrust, adjusting brake shoes      | 32 Washer, outside, speedometer gearbox         |
| 13 Expander, for brake shoes              | 33 Nut, locking, speedometer gearbox            |
| 14 Spacer, for cover plate, inner         | 34 Spacer, on spindle, speedometer gearbox side |
| 15 Bolt, retaining, sprocket to hub shell | 35 Spindle, rear wheel solid                    |
| 16 Sprocket and brake drum                |   |
| 17 Washer, sprocket retaining bolt        |   |
| 18 Nut, sprocket retaining bolt           |   |
| 19 Ring, spring, locating bearing         |   |
| 20 Cup, for bearing oil seal              |   |

## BRAKES

### Lightweight Scrambler and 350 c.c. Trials Model

**The front brake.** The front brake is dimensionally the same as the rear brake.

Brake adjustment to compensate wear on the linings is effected by finger adjustment on the rear brake rod and front brake cable.

After considerable mileage, brake lining wear will adversely affect the leverage of the brake shoe expander.

To restore the leverage without relining the brakes, packing washers 000174 are used under the heat treated thrust studs. The washers used must be uniform in thickness, to ensure both brake shoes make contact with the drum simultaneously.

### Heavyweight Models

**Front brake.** The front brake drum is cast in the hub and is machined after the wheel has been built, thus ensuring concentricity. During the process of lacing the wheel spokes, slight distortion can take place. If a wheel is rebuilt and brake efficiency is impaired, the brake drum should be skimmed to restore efficiency.

**Front brake cover plate.** The brake cover is located by a nut 021931 at the back of the plate. This nut is adjusted so that the plate when assembled is flush with the edge of the hub shell. The plate lock nut 018071 is fitted with the hexagonal side against the plate.

**Water enters the brake.** Check the location of the cover plate for correct position.

**Centralising the brakes.** For maximum brake efficiency both brake shoes must contact the drum simultaneously when the brake is applied. Release the spindle nut, also the cover plate lock nut. Closely adjust the brake cable and put pressure on the brake lever. Whilst maintaining the pressure, retighten the lock nut and spindle nut, this action will allow close adjustment of the brake shoes, without binding.

In exceptional cases the hole in the plate for the wheel spindle can be enlarged a slight amount.

**Removing the plate lock nut.** If there is difficulty in releasing this nut and a vice is not available, put the wheel spindle into one of the fork slider caps, with wheel outside the forks and tighten the clamp nuts, which will act as a temporary vice.

**Rear brake.** The rear brake drum is detachable. The front and rear brake shoes are interchangeable. See details for Scrambler brake for brake shoe adjustment.

### WHEELS AND BRAKES 1963 Heavyweight Models

For the 1963 season all models were fitted with journal type wheel bearings, as opposed to the taper roller type previously used. No adjustment to these bearings is possible, or necessary; the only attention needed is to renew lubricant and clean every 10,000 miles, the bearings being lubricated on initial assembly.

**The front wheel.** Two journal bearings type RMS 6 are used in the front

hub with a pull-out wheel spindle. A super oil seal is fitted against the bearing on the brake drum side to prevent grease entering the brake drum.

A similar oil seal is used in the bearing retaining sleeve at the opposite end of the hub, also a felt sealing ring.

The hub is packed with grease during assembly, subsequent lubrication should not be necessary until the machine has covered 10,000 miles, when the bearings can be re-greased if necessary. (See table of lubricants.)

**To remove the front wheel.** With the machine on the centre stand, disconnect the front brake cable from the brake expanding lever, then remove the bolt (securing the torque stay) from the brake plate and release the spindle nut 000001.

Remove the four nuts securing the detached fork slider caps, take off both slider caps, when the front wheel can be removed.

**Dismantling the front hub.** Both wheel bearings are a press fit into the hub.

To avoid "scruffing" the bearing housings in the hub during the process of removing and refitting the bearings, the hub must be gently heated to cause the hub material to expand and relieve the interference fit. Have available a new oil seal 029263.

With the front wheel removed, take off the spindle lock nut 029246, pull out the spindle and brake plate.

Remove oil seal collar 029262.

Prise out the oil seal 029263.

Gently heat the hub in the vicinity of the wheel bearing 029264 (do not concentrate the applied heat in one place) drop the hub on to a flat wood bench, when the bearing will move away from the centre of the hub. Invert the hub, use a suitable drift to drive out the bearing, placing the drift on opposite sides of the bearing so that it is extracted parallel with its housing.

Pull out the bearing spacing tube 029266.

Remove the lock ring *lefthand thread* 029238, also the hub disc.

Unscrew the bearing retaining sleeve 029269.

Re-heat the hub and drift out the second bearing as described for the first one.

**To assemble the front hub.** Gently heat the right side of the hub, insert the bearing and press it fully home by screwing in the bearing retaining sleeve (*lefthand thread*). Invert the hub and pack some grease against the bearing just fitted. Insert the bearing spacing tube and fill some more grease to the hub. Re-heat the brake side of the hub, insert the bearing and press it fully home.

Fit the oil seal (metal backing outwards) flush with the hub.

Fit the hub disc and secure it with the lock ring.

Insert the oil seal collar into the oil seal, put the spindle through the brake plate and the hub and tighten the spindle fixing nut.

**Refitting the front wheel.** Refit in the reverse sequence given for removal, with the following precautions: Ensure the bolt fixing the brake torque arm to the brake plate is securely tightened. Do not over tighten the four nuts securing the two fork slider caps.

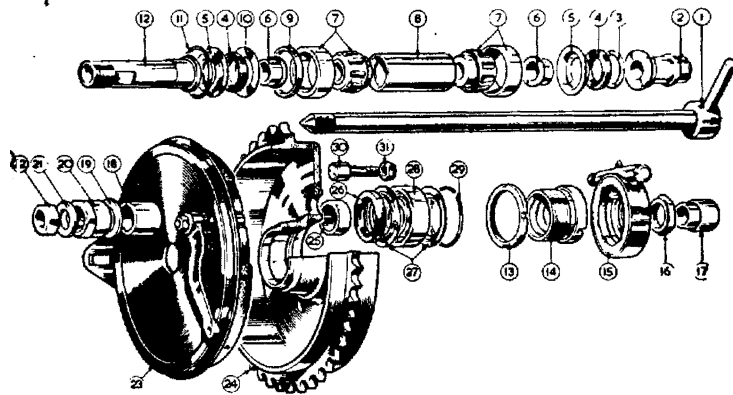

FIG 28 Rear brake and wheel bearings, de-luxe models

- |                                       |                                       |
|---------------------------------------|---------------------------------------|
| 1 Withdrawable wheel spindle          | 17 Spacer for withdrawable spindle    |
| 2 Speedometer gear box sleeve         | 18 Outer spacer for brake cover plate |
| 3 Ring retaining oil seal (small)     | 19 Washer for cover plate fixing nut  |
| 4 Oil seal                            | 20 Brake cover plate fixing nut       |
| 5 Cup for oil seal                    | 21 Spindle end washer                 |
| 6 Oil seal distance piece             | 22 Spindle end nut                    |
| 7 Taper roller bearing complete       | 23 Brake cover plate complete         |
| 8 Spacer between bearings             | 24 Rear brake drum                    |
| 9 Bearing spacing collar (brake side) | 25 Inner spacer for brake cover plate |
| 10 Ring retaining oil seal (large)    | 26 Brake drum bearing oil seal        |
| 11 Circlip                            | 27 Brake drum oil seal washers        |
| 12 Brake drum dummy spindle           | 28 Brake drum ball bearing            |
| 13 Lock nut for adjusting ring        | 29 Circlip retaining bearing          |
| 14 Adjusting ring                     | 30 Driving peg (5 off)                |
| 15 Speedometer gear box complete      | 31 Nut securing driving peg (5 off)   |
| 16 Speedometer gear box fixing nut    |                                       |

**The rear wheel.** A journal type bearing RMS 5 is used in the right side of the rear wheel hub, also a roller type bearing CRL 8 in the brake drum. The pull-out spindle passes through both bearings and the hub.

The wheel is detachable from the brake drum.

**To remove the rear wheel.** Using the box key 029385 (supplied with the tool kit) remove the five extended nuts 029235.

Remove the wheel spindle nut 014869, pull out the wheel spindle, when the speedometer drive will come away from the hub with the drive cable attached.

Slide out towards the rear spindle distance piece 029243, the wheel will now come away from the brake drum.

If the machine is leaned over on the right side, the wheel will come out under the brake drum.

**To re-fit the rear wheel.** Put the wheel back, insert the spindle through the frame and hub (without the distance piece of speedometer drive), which will help to line up the wheel.

Fit the five extended nuts and screw home lightly.

Take out the wheel spindle, fit the distance piece, put back the spindle with speedo drive through the hub and frame.

Position the speedometer drive and cable, re-fit and tighten the wheel spindle nut. Now firmly re-tighten the five extended nuts.

**Dismantling the rear hub.** With the rear wheel removed, unscrew the bearing retainer sleeve 029236 (*lefthand thread*) together with the oil seal and distance piece, which will come away with the retainer. Invert the hub, extract the circlip 029234 (use round-nose pliers) take out the distance piece 029231.

Gently heat the hub in the vicinity of the bearing 029233, drift out the bearing.

**Removing the oil seal 029237.** Tap the oil seal distance piece out of the bearing retainer, which will dislodge the oil seal.

**Rear brake drum.** To remove the roller bearing, use a suitable drift or a piece of steel tube to drift out the roller bearing. Invert the brake drum and press out the oil seal.

## WHEELS AND BRAKES 1964-1966

**To remove the front wheel.** With the machine on the central stand: Detach the brake cable from the expander lever. Detach the brake cable adjuster from the brake plate. Detach the right hand spindle nut. Release the pinch stud in left fork slider end. Take the weight of the wheel by the left hand, pull out the wheel spindle. The wheel can be taken out of the forks.

**To refit the wheel.** Reverse the procedure described for removal, with the following precautions. Remove traces of rust from spindle and grease. Exercise care to correctly locate brake plate in the fork slider. Do not tighten unduly the slider pinch bolt, overtightening can cause a fracture.

**NOTE**—If the fork motion is stiff after refitting the wheel, slack off the spindle nut and work the forks up and down (the fork tubes will take up alignment), then retighten the spindle nut.

**To remove the rear wheel.** The rear wheel is detachable from the brake drum. With the rear wheel clear of the ground: Take out the three rubber grummets (4). Remove the sleeve nuts (8) which retain the wheel to the brake drum. Unscrew the wheel spindle (20) and remove it. Take away the distance piece, between the speedometer drive, which will come away also, there is no need to separate the cable from the drive. Pull the wheel away from the driving studs in the brake drum. Incline the machine to the right side, then pass the wheel under, clear of the machine.

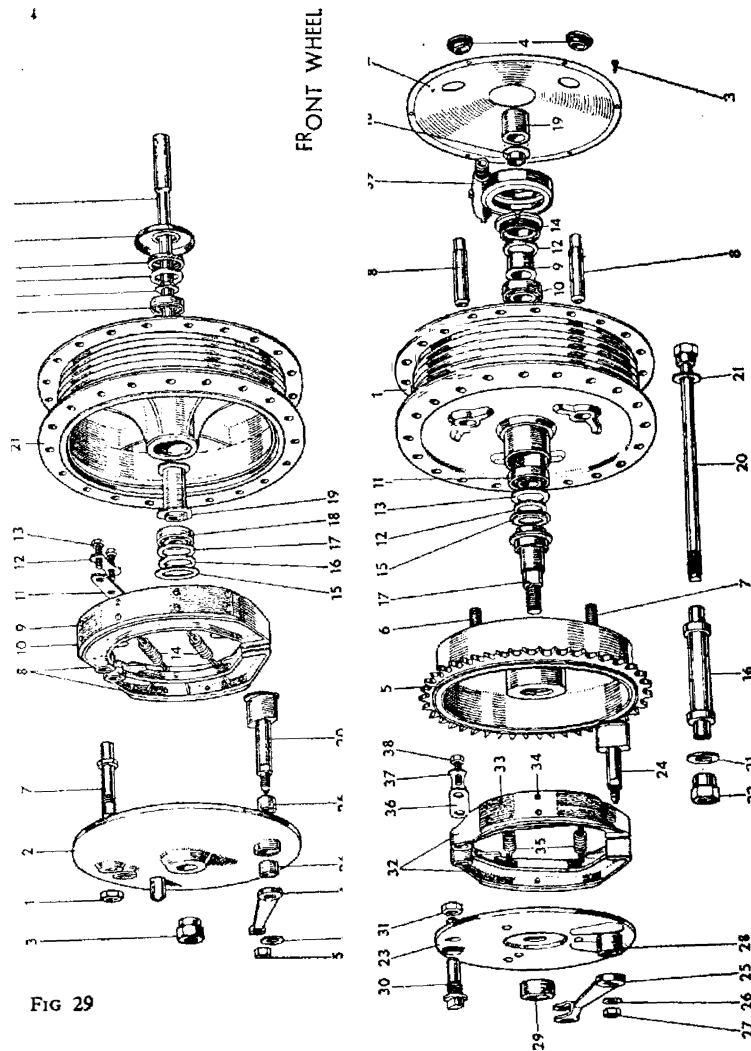

FIG 29

**To remove the brake drum.** With the rear wheel removed: Take off the brake rod hand adjuster, then remove the rear chain connecting link. Release the nuts securing the dummy spindle, pull back the brake drum clear of the fork ends.

**To dismantle front hub.** The wheel hubs are packed with grease during initial assembly, and should not need further lubrication for at least 10,000 miles, when the hubs should be dismantled for cleaning and fresh grease used. To dismantle the front hub, with the wheel removed take away the brake plate with brake shoes.

Unscrew bearing lock plate on left side of hub, holes are provided for a peg spanner or use a punch. If the plate resists removal use a little heat which will facilitate removal, take out felt sealing washer and distance piece.

To eject the bearings use a drift through the brake side (the front wheel spindle can be used for this purpose) when a few light blows from a mallet will drive out the bearing until it is clear of the hub, and no more, as the other bearing goes into the hub during this process.

Take out the spindle, or drift, invert the wheel and repeat the process to eject the double bearing which will bring with it the large steel washer, the felt washer, also the thin steel washer.

**Assembling the hub.** Clean and repack both bearings with fresh grease (see table of lubricants). Press into the left side of the hub the single bearing, fit the distance washer (flat side against the bearing), then the felt washer and secure with the lock plate.

Invert the hub, insert the distance tube (small end first) against the bearing.

Enter the double bearing square with the hub, use a drift through both bearings and drive home until the bearing abuts against the distance tube.

Fit the smallest of the two washers, the felt washer, then the large steel washer.

With a suitable punch peen the hub material, where it joins the washer in three equi-distant positions to retain the washer.

**Rear hub dismantling.** With the wheel removed, remove the speedometer drive lock ring (this has a *lefthand thread*), take out felt washer and distance piece. To eject the bearing use the wheel spindle with its washer also the distance piece that goes between the speedometer drive and the frame placed on the spindle. Partially drive out the bearing until it abuts against the reduced diameter inside the hub. Take out the spindle, use a short length of steel tubing with the outside diameter slightly smaller than the inside diameter of the bearing and drive out the bearing.

Invert the wheel, then drift out the other bearing, which will take with it the steel cup, felt washer and the thin steel washer.

**Assembling the hub.** Deal with the bearings as already described and assemble by first fitting the single row bearing, in the reverse order described for dismantling, with the following precautions: when tightening the *lefthand* lock ring avoid damage to the slots for the speedometer drive. Finally "peen" the hub dished washer to the hub. The hub assembly sequence is shown in Fig. 29.

**Dismantling the brake drum.** A bearing is not used in the brake drum:



when the spindle nut is removed together with the spacer and washer, the spindle can be taken out.

**Balancing the wheels.** At high speeds, if the tyres are out of balance, the steering can be affected and in extreme cases the front forks can 'flap' at maximum speed. As oil seals are used on both wheel spindles, the wheel cannot be accurately balanced until the friction caused by the seals is removed. The courses open are:

(1) Remove the oil seals.

(2) Obtain two ball races with an internal diameter sufficiently large enough to take the wheel spindle, mount the wheel on two boxes.

If the wheel is correctly balanced, it should remain stationary in any position in which the wheel is placed. The most likely out of balance position will be where the valve is situated or where a security bolt is fitted. The heaviest part will of course come to rest at 180° or 6 o'clock. To counter-balance, use thin strips of lead twisted round the spoke. Special weights for this purpose are supplied by the tyre makers. When the wheel is in perfect balance, secure the strips of lead with insulating tape which should be painted with jointing compound. The effect of a balanced wheel has to be tried to be appreciated if continued high speeds are permissible.

#### Lightweight Models

**To remove front wheel (1959 type).** With front wheel clear of the ground, run back the brake cable adjuster, disconnect the cable.

Release the two nuts securing the guard stay.

Give both nuts a sharp tap to centralise the stays.

Take off both spindle nuts, the wheel will come out of the sliders.

**To remove front wheel (1960-1961 type).** A pull out spindle is used on these models. Follow instructions for earlier type wheel, then remove the right side spindle nut and pull out the spindle. A tommy bar can be used in the spindle hole provided.

**To remove front wheel (250 c.c. Scrambler).** Refer to details given for the Heavyweight Models as the wheel arrangement is identical.

**To remove front wheel (350 c.c. Lightweight Model).** Disconnect brake cable, take off nut securing brake torque arm to brake.

Release the spindle nut, take off the two caps on the slider ends, the wheel will come out.

**To remove rear wheel (Lightweight Model).** Remove rear chain guard.

Remove speedo drive cable.

Remove chain connecting link.

Remove rear brake rod adjuster.

Release both wheel spindle nuts, pull the wheel clear of the fork ends. Standing on the left side lean the machine to the left and take out the wheel.

When refitting, take care to carefully locate the dogs for the speedo drive into the slots in the hub.

**To remove rear wheel (Scrambler Model).** Remove rear chain connecting link.

Remove rear brake rod adjuster.

Remove speedo cable.

Release wheel spindle nuts, pull the wheel to the right to clear the brake anchorage and pull back the wheel.

Take the wheel out on the right side of the machine.

#### Wheel Bearings Lightweight

**Front wheel (1959 Model).** Remove the brake cover plate assembled, then knock out the wheel spindle which will eject the bearing, the oil seal and cup.

**Front wheel (1960-62 Models).** (Fig. 30). It will be seen that the outside diameter of the spacing tube (13) is nearly the same as the inner member of the bearing (12). In consequence the projection into the spacing tube is small.

Use a steel rod with a square end, inserted through the inner member of nearest bearing and 'feel' for the projection. One or two blows on the rod with a light hammer will dislodge the bearing and bring with it the oil seal and cup.

**Rear wheel (all Models).** Use the method detailed for the 1959 front wheel bearing.

#### 250 c.c. CSR Model

**Removing the front wheel.** Disconnect front brake cable at wheel end.

Disconnect brake torque arm by removing bottom fixing bolt.

Remove front wheel spindle nut.

Remove four nuts securing fork slider clamps.

Remove both clamps, the wheel can now be removed.

**Front brake.** The air vent slots are intentionally sealed to prevent entry of water. For competition work the metal seal can be removed by a pen-knife passed through the vent slots.

**Front wheel bearings.** These are journal type and no adjustment is necessary. The bearings are pre-packed with grease on assembly.

Bearings should be cleaned and re-greased at five to eight thousand miles.

**Bearing assembly.** The assembly sequence is in the following order:

Oil seal cap.

Oil seal felt washer.

Oil seal collar.

Oil seal thin washer.

Bearing SKF 6302 (02).

A spacing tube separates the two bearings, both assemblies are identical.

**Removing front wheel bearings.** Use a steel rod or bar with a section of  $\frac{1}{4}$ ". Insert this tool half-way inside the hub and lever it sideways, which will move the bearing spacer tube.

Place the tool on the bearing ring and drift out, moving the tool from one side of the bearing ring to the other.

**Brakes (Lightweight Models).** The front and rear brake shoes are identical and interchangeable.

When new linings are required and when possible, service exchange brake shoes should be used.

Factory serviced shoes are ground on a fixture, so that the linings

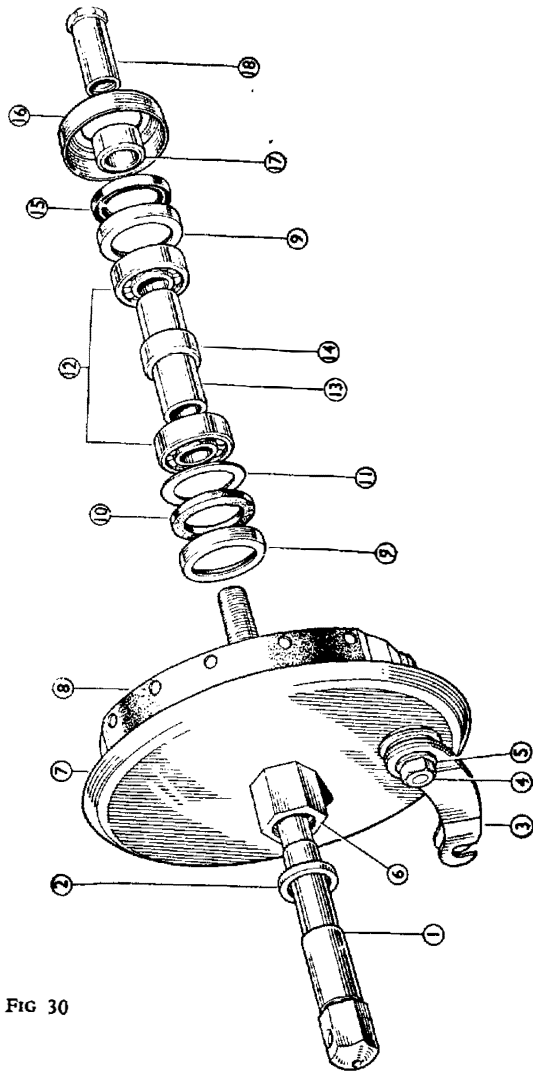

FIG 30

Key to FIG 30  
1960-62 front hub assembly

- |   |                              |
|---|------------------------------|
| 1 Spindle, front wheel                        | 9 Enclosure cup, oil seal    |
| 2 Washer, front wheel spindle (350 c.c. only) | 10 Seal, felt, for bearing   |
| 3 Lever, brake shoe expander                  | 11 Washer, bearing felt seal |
| 4 Nut, brake shoe expander lever              | 12 Bearing, for hub          |
| 5 Washer, brake shoe expander lever           | 13 Spacing tube, bearing     |
| 6 Spacer, hexagon, front cover plate          | 14 Pressing, spacing tube    |
| 7 Cover, front brake plate                    | 15 Seal, rubber, for bearing |
| 8 Brake shoes, pair                           | 16 Enclosure cap             |
|   | 17 Spacer, front spindle     |
|   | 18 Nut, front spindle        |

will be concentric with the brake drum, with immediate efficiency, providing the brake drum is not badly scored.

The brake drums are not detachable.

If braking efficiency is impaired by reason of over greasing the wheel hub, the brake shoes should be de-greased and not treated with petrol or paraffin, which only tends to make the grease more fluid.

Contrary to general belief, a smooth surface on the brake linings gives the best braking.

**Centralizing the brake shoes.** If the rear wheel and the brake cover plate has been disturbed, when the wheel is refitted leave the spindle nut 043303 and lock nut 043305 slightly loose.

Press hard on the rear brake pedal, tighten the lock nut whilst pressure is maintained.

The fact of opening out the spindle hole in the cover plate to the extent of  $\frac{1}{32}$ " will ensure centralization.

**Brake squeal.** Check linings and drum for dust from linings. Centralize brake shoes or fit new type rear brake expander lever 043419, which will also improve braking efficiency.

**Wheel bearings (Lightweight Models).** Two journal bearings at each end of the hub are a press in fit. The bearings are greased when assembled. The bearings should be cleaned and re-greased every 4,500-5,000 miles. Use grease of the anti-centrifuge type for these bearings.

If wear develops on the right-hand front wheel bearing, entry of water is the cause. Fit the new water excluder 043420 to shroud the bearing.

Discard cover 043282 and spacer 043358.

**Wheelbearings (250 c.c. Scrambler).** Taper roller bearings similar to those used on the Heavyweight Models are fitted to both wheels. The outer cups are pressed into the hubs.

These bearings rarely need adjustment, providing grease is applied via the nipples on the hub, say every 1,000 miles.

For service details see Heavyweight Models.

**Speedometer gear box lubrication.** Where a grease nipple is not fitted, periodical lubrication is not necessary as the drive parts are made from self-lubrication material. A little oil on the seal is beneficial when the drive is removed from the wheel.

## TRANSMISSION

### Heavyweight Models

**Front chain adjustment.** The Scrambler Models use a chain adjuster on each side of the gear box, to prevent the gear box from moving.

Remove the engine plate cover, also inspection cap on chaincase.

Slack off the clamp bolt.

To tighten the chain: Screw down the adjusting bolt. Press down the rear chain to pull the gear box backwards.

Check the chain tension, which, if correct, should have a whip of  $\frac{3}{4}$ ".

If the chain is too tight, unscrew the adjusting bolt a little at a time, until the adjustment is correct.

Check the tension in several places. Chains do not always stretch evenly. Retighten the nuts.

Now check the rear chain adjustment.

**Chain case oil level.** With the machine vertical and on both road wheels, the bottom run of the chain should just touch the oil.

**Rear chain adjustment** (quickly detachable wheel). To take up slack or tighten the rear chain and with the machine on the central stand:

Release slightly the spindle nut (22) and the dummy spindle nut (20).

Run back the lock nuts on the two chain adjusting bolts through fork ends, unscrew each adjusting bolt a trifle at a time, also an equal amount, until the chain whip taken in the centre of the bottom chain run is  $1\frac{1}{4}$ ". Check the tension in one or more places.

As an alternative and possibly the best method is to have this adjustment made with the machine on its road wheels and the rider seated, when the chain whip should be  $\frac{1}{2}$ ". Retighten the release nuts when the adjustment is correct, then check the rear brake adjustment, which will be affected when the wheel position is altered.

**Rear chain adjustment** (non-quickly detachable wheel). Release the spindle nut (1) and adjust the chain as already described.

**Removing the front chain.** Follow details for removing engine from frame. When refitting the chain the closed end of the spring link should face the direction of rotation.

**Removing the rear chain.** The rear chain is closely shrouded by the chain guard, which leaves little room to operate, other than releasing the chain guard from its fixings. If a new chain is to be fitted, disconnect the connecting link in the fitted chain and connect it to the new chain at the top run. Select a neutral position in the gear box then with the left hand holding the bottom chain run and the top with the right hand, the new chain can be pulled into position until the chain joint is accessible, when the connecting link can be fitted.

**NOTE**—The closed end of the spring link should face the direction of rotation.

If a second chain is not available, use a piece of string 10 ft. long, take out the connecting link and pass one end of the string through the link hole. Pull on the string until both ends meet and tie them together.

Pull on the bottom run of the chain, with one hand, keeping the string taut with the other hand.

As the chain leaves the gear box sprocket, the string will be each side of the sprocket teeth.

When the chain is well clear, cut one piece of the string about one foot from where it passes through the chain.

Detach the chain, leaving the string in position.

**To refit the chain.** Pass the longer end of the string through the chain and tie the ends together. Now pull on the string, guiding the chain until it encircles the gear box sprocket. Continue pulling until the top run encircles the rear wheel sprocket and fit the connecting link.

### Lightweight Models

**Front chain adjustment.** Remove inspection cap from front chaincase; remove the two securing screws on the rear engine cowling; lift the cowling to expose the gear box adjuster bolt.

Slacken nut on left-hand side of gear box top fixing bolt.

Slacken two clamping strap bolts.

Adjust chain by means of adjuster eye-bolt 043938 and two nuts. (The correct whip is  $\frac{3}{4}$ ".)

Check the adjustment in several positions and adjust at tightest part of chain.

Tighten two clamping strap bolts, top gear box fixing bolt.

Refit rear engine cowling and securing screws.

Replace chaincase inspection cap.

**NOTE**—After adjusting front chain, check rear chain adjustment.

**Removing the front chain (350 c.c. and 250 c.c. CSR Models).** The front chain fitted to this model is duplex and endless, which means that the clutch sprocket, also the engine sprocket must be withdrawn simultaneously if the front chain is to be removed. To proceed, follow the instructions given for dismantling the clutch, as far as removing the gear box main axle shaft nut. Then remove the nut and washer retaining the rotor to the driving side engine shaft, take out the key for the rotor from the shaft. The engine sprocket and clutch, together with the chain in position, can then be withdrawn.

**NOTE**—One or more shim washers may be fitted at the rear of the engine sprocket, which must be replaced during assembly.

**Rear chain adjustment.** Prior to adjusting rear chain, check front chain and adjust if required.

Loosen both nuts on the rear wheel spindle.

Loosen lock nuts on the adjusters and turn the adjusters until correct chain adjustment is obtained, taking care to move both adjusters exactly the same amount to maintain wheel alignment.

While on the stand the chain whip should be  $\frac{3}{4}$ " to ensure  $\frac{1}{2}$ " whip when rider is seated.

Check the adjustment in several positions and adjust at tightest part of chain.

Remove the rubber cap on the totally enclosed chain guard to check chain tension.

Retighten wheel spindle nuts, and adjuster lock nuts.

**NOTE**—After chain adjustment rear brake should be checked and re-adjusted as necessary. See 'Brake adjustment'.

**Removing and refitting rear chain.** To protect the rear chain from mud and water it is very closely shrouded by the chain guard and removing the chain without first detaching the chain guard, can present considerable difficulty. A simple procedure, however, is as follows:

First obtain a piece of thin string about 10 ft. long.

With cycle on the stand turn the rear wheel until the chain connecting link is at a position near the rear sprocket, and remove the connecting link.

Now pass the string through the centre hole of the end link of the top run, draw the two ends of the string level and tie together.

Then pull the bottom run of the chain backwards with one hand while keeping the string taut at the rear end with the other hand.

As the end of the top run of the chain disengages with the gear box sprocket it will leave the string attached lying one strand each side of the sprocket teeth.

When the chain is well clear cut the string one side only at a point about one foot from where it is looped through the chain link.

Leave the string then *in situ* awaiting chain refitting.

To refit the chain: pass the longer cut end of the string through the centre hole of the end chain link and then tie the two loose ends of the string together. Then pull the string from the rear end, at the same time guiding the chain up to engage with the gear box sprocket.

Continue pulling until the chain encircles the sprocket. Remove the string, refit the connecting link with the spring clip closed end facing direction of rotation.

**To remove the rear chain guard (fully enclosed type).** Remove bottom fixing nut on left-hand rear suspension unit, and slide the lower end of the unit off the stud, slacken the left-hand wheel spindle nut. Remove the two chaincase securing bolts. The large spindle washer is used outside the guard.

The top and bottom halves of the chaincase can then be removed.

**Open chain guard.** Remove bottom fixing nut on left-hand rear suspension unit and slide the lower end of the unit off the stud. Remove rear brake rod adjuster nut, rear chain and speedometer cable, slacken wheel spindle nuts. Remove the two chain guard securing bolts, lift the rear of the chain guard and slide the rear wheel out of the fork ends. The rear chain guard can now be removed.

Reverse this procedure for reassembly.

**Front chaincase oil seal.** The felt washer in the rear half of the chaincase, for the gear box mainshaft is fitted before the plates are spot welded. If this seal is unserviceable, take a new felt ring and using a razor blade, cut the new one into two. The ring half its normal thickness can be pressed between the steel plates.

## CARBURETTER

### Carburetter tuning information

Poor idling may be due to:

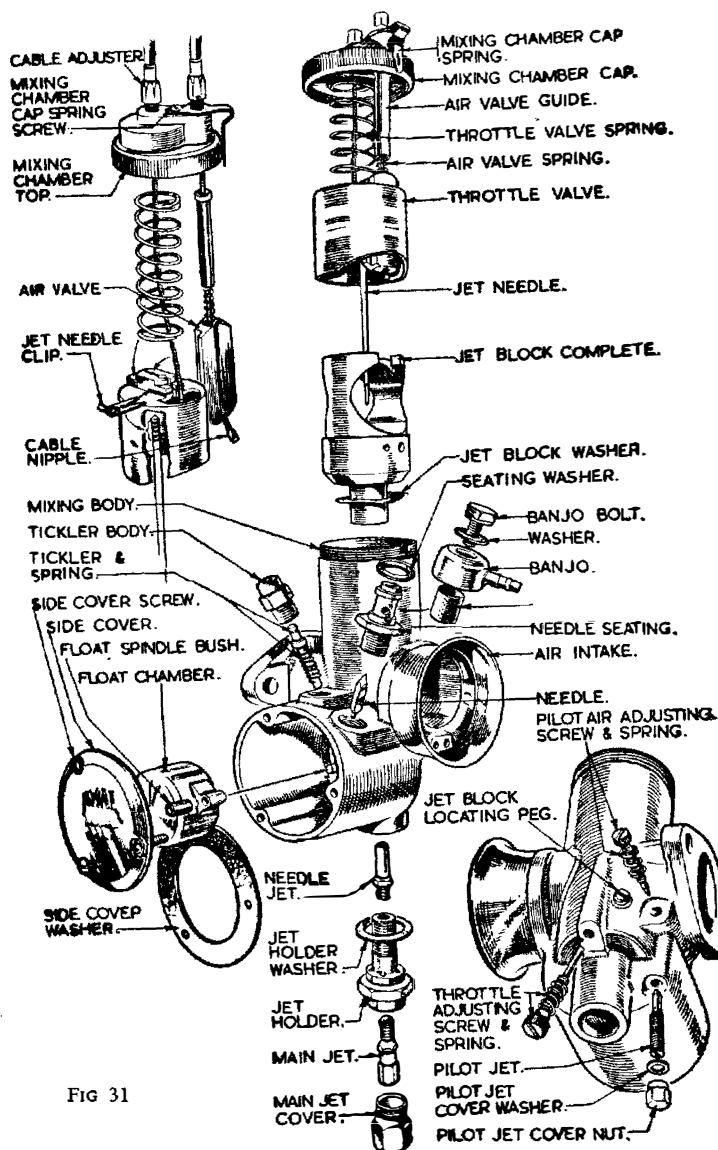

FIG 31

Air leaks either at junction of carburetter and inlet manifold, or by reason of badly worn inlet valve stems or guides.

Faulty engine valve seatings.

Spark plug faulty, or its points set too closely.

Ignition advanced too much.

Contact breaker points dirty, pitted, loose or set too closely.

High-tension wire defective.

Pilot jet not operating correctly. Partially choked or incorrect air supply.

Rockers adjusted too closely.

Heavy petrol consumption may be due to:

Late ignition setting.

Bad air leaks. Probably at carburetter or manifold joints.

Weakened valve springs.

Leaky float (causing flooding).

Taper needle extension insufficient.

Poor compression, due to worn piston rings or defective valve seatings. (Test compression with throttle wide open.)

**Carburetter flooding.** If the carburetter is flooding, the float spindle bush (Fig. 31) may be pinched between the float swivel and the float chamber cap.

Reduce slightly the width of the tube or renew the gasket for the cover.

Exercise care to avoid over tightening the pilot jet which can deform its seating in the mixing chamber. A defective jet block fibre washer will allow fuel to leak across the choke.

**Notes on carburation.** The main jet originally fitted is deemed to be the most suitable. There should be no necessity to alter the main jet size without good reason, i.e. by fitting an air filter, running with an open exhaust pipe system or at specified altitudes.

Riders with considerable experience can, after driving at full throttle for at least a third of a mile decide, after 'reading' the sparking plug if the main jet size is suitable or otherwise.

Without such experience it is preferable to drive at full throttle and close the air lever  $\frac{1}{4}$ ". If the engine speed increases, the main jet is small. Conversely, if the engine speed decreases, the main jet is large.

Jet alterations should be made in stages of 10 c.c. increase in jet size, viz. size 200 to 210.

### WIPAC ALTERNATOR

The series 114 Alternator consists of a six pole Stator ring 5" in diameter with six coils and a six pole permanent magnet rotor. There are three main leads coloured white, light green and orange. Three coils are connected in series to white and light green, the other three coils are connected in series to white and orange. The output from these coils is a.c. converted to d.c. by means of a bridge-connected metal rectifier. The output of the alternator is controlled through the switch on the headlamp and connects three or six coils according to its position.

**Emergency starting.** The emergency position is intended for starting when the battery is discharged. This position is marked 'EMG' on the ignition switch.

In this position the two groups of alternator coils are connected in parallel, and if the lights switch is in the 'OFF' position the full output of the alternator goes into the battery. This will raise the voltage of a discharged battery to a level sufficient to start the engine. In the EMG position the charge rate is high—the engine should not be run in EMG too long. The boost charge thus provided may be used to restore a discharged battery. Switch over to IGN after ten minutes.

**Rotor demagnetised.** Although the WIPAC Rotor is robustly built and holding a very high magnetic charge, it can become demagnetised if the machine is run with battery connections reversed, or if the rectifier breaks down. A demagnetised rotor should be returned to WIPAC for satisfactory remagnetisation.

**Testing.** Testing of component parts can be carried out if the following instruments are available:

0-12 d.c. Volt Meter.

0-15 a.c. Volt Meter.

1 ohm Resistor (capable of carrying 8 amps.).

10-0-10 d.c. Ammeter.

High grade and accurate moving coil instruments must be used. The 1 ohm resistor must also be accurate, otherwise correct readings cannot be obtained. *Engine speed* when testing should be in the region of 2,500 r.p.m. Tests should not be attempted at speeds below 2,000 r.p.m. A few revs. above or below 2,500 will not affect the readings of an alternator in good condition.

**Charge rate test:**

(1) First check the battery voltage which, if fully discharged, should be substituted for one that is in good condition.

(2) Disconnect the brown negative lead from the double connector.

(3) Connect the d.c. ammeter in series with the battery wire and the double connector.

(4) Run the engine at 3,000 r.p.m., the minimum permissible readings are shown in the following table:—

Ignition switch	Lights switch	Minimum charge rate
Ignition on	Off	1.0a
Ignition on	Low	1.3a
Ignition on	High	1.0a
Emergency on	Off	6.0a

The rate of engine speed and condition of the battery will affect the charge rate recorded. The figures shown in the table in comparison with the recorded figures indicate if the system is functioning correctly.

**NOTE**—If the charge rate is down with lights on HIGH check the main bulb wattage.

**Low or no charge rate test.** Check the alternator output by:

(1) Disconnect the white, orange and light green wires from the four-

way connector. If a maroon colour lead is also used, leave this in position.  
 (2) Using the a.c. voltmeter with the one ohm. resistor across the terminals (parallel) join one wire from the voltmeter to the white wire, the other meter wire to the orange wire. Run the engine at a speed equivalent to 30 m.p.h. in top gear, the voltage reading should be between 6.2 and 6.8 volts.

Transfer the meter wire from the orange wire to the light green and repeat the test. A low reading on one of these tests indicates a fault in the coils. A low reading on both tests can be due to a partially demagnetised rotor.

If no reading is shown on both tests, the alternator is defective (see test 3).

(3) A short circuit to earth on one or more coils will affect the a.c. voltage output.

To check, with the front chain case in position, use the d.c. voltmeter in series with a battery in good condition. Connect the wire from the meter to the white wire, the battery wire to a good and convenient earth on the engine. If a reading is shown on the meter, one or both coils are shorting to EARTH.

**NOTE**—The white wire is common to all coils.

Remove the outer portion of the chain case, check the alternator wires for damaged insulation, also coil connections before discarding the alternator.

When the fault is located, repeat the tests previously described.

**Rectifier tests.** Before testing, verify the earth connection is clean and secure. Check also the wires attached to the rectifier for loose connections. Take out the white, green and brown wires from the rectifier.

For this test use a 6 volt battery connected to a 3 watt bulb and holder.

Test in the following sequence:

Positive wire to	Light Green	} Bulb earthed. Bulb lights.
" " "	White	
" " "	Brown	} Bulb on Green. No light.
" " "	Brown	
		} Rectifier faulty.
Reverse the battery connections with:		
Negative wire to	Light Green	} Bulb earthed. No light. Rectifier
" " "	White	
" " "	Brown	} Bulb on Green. Bulb lights.
" " "	Brown	

**NOTE**—The common cause of rectifier trouble is invariably due to reversed battery connections, which can also demagnetise the rotor, if the engine is run with these connections reversed. The battery positive terminal is connected to EARTH (translucent), the negative is the feed line (brown).

**Ignition and lighting switches.** Both switches in the head lamp are

mechanically identical and will interchange, the switch knobs being differently marked. If one switch is suspect, take off the lamp rim and glass. Pull off the cable plugs and reverse their location. A further check will indicate if the switch is defective or otherwise. Replace the cable plugs in correct position after changing the switch.

Replacement switches should be of the improved type which can be identified by a NYLON post for the switch knob. Old type switches use a steel post.

**Plug location.** The blue plug is for the lighting system and the black for ignition.

### WIPAC ELECTRICAL SERVICE

**Lamp bulb 'blowing'.** Premature bulb failure involving all or many of the light bulbs at one time on a full d.c. battery system is caused by a defective connection in the battery 'line'.

This 'line' starts at the frame end of the translucent lead from the positive battery terminal and proceeds:

- (2) Positive battery terminal.
- (3) Negative battery terminal.
- (4) Brown wire from battery negative to 4-hole connector (bullet terminal).
- (5) Brown wire from 4-hole connector to ammeter (bullet terminal).
- (6) Ammeter terminal with brown wire.
- (7) Ammeter terminal with blue wire.
- (8) Both ends of short insulated link wire in the ignition switch plug, which joins blue ammeter wire to brown wire going to lights switch.

Should the ammeter develop internal open circuit, bulbs will blow, also should the battery have little or no electrolyte, this is a partial or complete open circuit with the same results. There is finally the remote possibility of one of the actual wires in the battery 'line' being broken—again, bulbs will 'blow'.

For quick checking, test connections in this order:

- (1) Both battery terminals.
- (2) Both ammeter terminals.
- (3) All brown wires into 4-hole connector.

**Speedometer bulb.** On models made before 1961, the speedometer bulb is in circuit during daylight running and fails from filament fatigue. Transfer the wire attached to the speedometer bulb holder and connect it to the light switch as shown in wiring diagram for 1962 models, to illuminate the speedometer when lights are in use.

**Ignition system.**

**SPECIAL NOTE**— The star-shaped washer for contact breaker pivot is not detachable. If the engine fails to start and there is no spark at the sparking plug points, examine the contact breaker by:

Check the gap at full separation .012" and reset if necessary (ensure feeler gauge is free from oil).

Check conditions of contact points which should have a grey frosted condition. The presence of oil or grease in the contact breaker compartment will cause a black matt condition.

Clean points with an abrasive strip or alternatively fine grade emery cloth. Pass a strip of clean paper, or rag soaked in petrol, across the points after cleaning.

Check free movement of contact breaker arm on its pivot.  
**Adjusting contact breaker gap.** This adjustment is effected by altering the position of the plate for the fixed contact point by:

- (1) Releasing slightly the locking screw.
- (2) Adjust the gap by turning the eccentric screw (close to the fibre pad) in the required direction, with the fibre pad on the rocker arm on the cam lobe (maximum separation) .012". Retighten the lock screw when adjustment is correct.

**Lubrication.** The felt pad should be impregnated with H.M.P. grease. Use sparingly, an excess can affect contact points surface.

Before replacing the contact breaker cover, check the condenser fixing for security.

If attention to the contact breaker fails to produce a spark, check the circuit by:

Switch on the ignition, rotate the engine very slowly until the contact points close. A discharge between three to four amps will be shown on the ammeter if current is passing.

As the ammeter is not closely calibrated, a more accurate check can be made by using the d.c. ammeter in between the brown battery wire and its connector.

If a discharge is not shown on the ammeter with contact points closed, this indicates current is not passing through the primary windings in the h.t. coil.

With ignition switch on check the dark green wire attached to the coil by:

Removing this wire from the coil terminal.  
Connect one side of the d.c. voltmeter to the end of the dark green wire, the other side of the meter to earth.

If there is no reading on the meter, check the ignition (black) plug in the headlamp.

If the internal insulated wire bridge across two of the plug terminals (see wiring diagram) is fractured or disconnected, this will allow the engine to start with the switch on either emergency or ignition, but not in both positions, as one switch connection is out of circuit

Renew the bridge connection.  
**Ignition coil test.**

(1) Use a battery with one wire attached to the d.c. voltmeter with a short length of wire attached to the other voltmeter terminal.

(2) Disconnect the two wires attached to the coil, also the h.t. cable.

(3) Use a further wire on the second battery terminal. Connect the free end of this wire, also the meter wire across the coil terminals. If there is continuity, a reading will show on the meter indicating the primary winding is in order.

(4) Transfer one wire from the coil terminal to the centre h.t. connection, if there is continuity a lower voltage reading will show by reason of the higher resistance of the secondary winding.

(5) Place one of the test wires on to one of the two coil terminals, the other to the coil case. No reading should show. Use the test wires on the h.t. connection and the case. No reading should show.

A meter reading on one or both tests means the windings are earthed, the coil should be replaced.

Usually a defective primary winding will produce a weak spark, conversely, an intermittent spark is associated with a faulty secondary winding. Where doubt exists, test by substitution.

**The condenser** (see 'Ignition system'). If the condenser is suspect, use a sound condenser with two crocodile clips attached to it.

Remove contact breaker cover, attach one clip to the connection on the contact breaker terminal, the other to a conventional earth position.

**Running the engine with the external condenser in use** will prove if the condenser is faulty or otherwise.

Vivid blue arcing at the contact points is indicative of a faulty condenser.

Where the orthodox electrical testing gear is not available, improvisation can be made using the following equipment:

- (1) A 6 volt 36 watt bulb and holder.
- (2) A 6 volt .04 amp bulb and holder (this bulb is used on cycle rear lamps).

(3) A fully charged 6 volt battery.  
(4) A short length of wire to join the battery to one side of the bulb holder. Also two test wires about 24" long connected to the other battery and bulb holder terminals.

Test to ensure the bulb lights then proceed by:  
Disconnecting the alternator wires from the connector.  
Join one test lead to the white cable, the other test wire to the green cable.

Run the engine at a fast tick over speed when the bulb should show a fairly bright light.

Transfer the test wire from the green cable only to the orange cable and repeat the test.

**Conclusions from test**  
(1) If the lamp bulb is not uniformly lighted on both tests, there is a fault in the alternator (see 'Earth test').

(2) Should the bulb fail to light, the alternator is defective.  
(3) A dull light on both tests indicates a partially demagnetised rotor, due to battery connections being reversed at some time or other. Use a.c. voltmeter to check voltage output.

**Alternator coils earthed.** Use the test set with the 6 volt .04 bulb.  
Connect one test wire to a convenient earth position on the engine.  
Connect in turn, the other test wire to the white, green and orange wires.

Should the bulb light on any of these tests, the coils are shorted to earth.

**Rectifier (forward flow test).** With the ignition and lights switches 'OFF', use the 36 watt bulb for this test, then:

Disconnect the wire from the brown connector on the rectifier (keep

the wire end clear of the frame and engine).

Connect one test lead to rectifier brown terminal, the other test lead to earth.

Switch on to EMG and run the engine at tickover when, if the rectifier is O.K., the bulb will light brightly (six coils in circuit).

Repeat the test with the switch at IGN (three coils in circuit), the bulb will light, but not so brightly if rectifier is O.K.

**Warning:** Do not attempt to run the engine with an open circuit for the rectifier. The brown wire or the test set must be connected to prevent high voltage which will cause damage.

**Rectifier (reverse flow test).** With the light and ignition switches 'OFF' test by:

Taking off one of the battery wires from the battery.

Connect the test set with the .04 amp bulb between the battery terminal and the battery wire.

If the reverse flow is normal, the bulb will light dimly, a bright light indicates a defective rectifier.

**Alternative rectifier tests.** An alternative method of testing can be effected by using the following equipment:

- (1) A moving coil ammeter, scale 10-0-10.
- (2) A fully charged 6 volt battery.
- (3) A 6 volt 30 watt lamp bulb and holder.
- (4) A 6 volt 0.04 amp bulb and holder.
- (5) Three short test wires.

**Forward flow test.** Make a series circuit. The bulb will light with a reading of approximately 4.5 amps on the meter.

Take off the wire from the positive battery terminal, connect the third test lead to the positive battery terminal, also to the brown terminal on rectifier (d.c. negative).

Take up the wire taken from the battery and connect in turn to the green, then white, terminals (a.c. side).

In each test the bulb should light with a reading of 4.5 amps on the meter.

For clarity, remove test wires from rectifier, remake the series circuit.

Next remove the battery negative wire, connect the third test wire to the negative battery terminal, also to the rectifier earth bolt or case.

Connect in turn the wire removed from the battery to the green and white terminals. Again, in each test the bulb should light with a reading of 4.5 amps.

If the meter readings on these tests are above 3 amps, the rectifier is satisfactory. Discard the rectifier if the readings are below 3 amps.

**NOTE**—Whilst a new rectifier will show 4.5 amps, this value will decrease after considerable service.

**Reverse flow test.** Make a circuit using .04 amp bulb for this test.

A rectifier that is normal will have a reverse flow which should not exceed 0.040 milliamps, by using the 0.40 bulb with a current consumption of 40 milliamps it can be established if the reverse flow is abnormal by:

Removing the positive lead from the battery.

Join the third test wire to the battery positive, also to the rectifier earth bolt or case.

Connect the wire removed from the battery, in turn, to the white and green terminals.<sup>†</sup>

If the bulb lights in these two tests the rectifier is defective.

Take off the test wires from rectifier and remake the circuit.

Remove the negative wire from the battery.

Join the third test wire to the battery negative terminal, also to the brown rectifier terminal.

Connect the wire removed from the battery in turn, to the green and white terminals.

Should the bulb light in either of these tests the rectifier is defective.

## LUCAS ELECTRICAL SERVICE

### Lucas A.C. Lighting-Ignition Unit Alternator Model RM15

The alternator consists of a spigot-mounted 6-coil laminated stator bolted to the outer portion of chaincase with a rotor carried on and driven by an extension of the crankshaft. The rotor has an hexagonal steel core, each face of which carries a high energy permanent magnet keyed to a laminated pole tip. The pole tips are riveted circumferentially to brass side plates, the assembly being cast in aluminium and machined to give a smooth external finish.

Thus there are no rotating windings, commutator, brush-gear, bearings or oil seals and consequently the alternator requires no maintenance apart from occasionally checking the snap connectors in the three output cables are clean and tight, which are located behind the frame cover which is located by two knurled screws.

If it is necessary, for any purpose, to remove the rotor, there is no necessity to fit keepers to the rotor poles. When the rotor is removed wipe off any metal swarf which may have collected on the pole tips. Place the rotor in a clean place.

**Normal running.** Under normal running conditions (i.e., ignition switch in IGN position) electrical energy in the form of rectified alternating current passes through the battery from the alternator—the rate of output depends on the position of the lighting switch. When no lights are in use, the alternator output supplies the ignition coil and trickle-charges the battery. When the lighting switch is turned, the output is automatically increased to meet the additional load of the parking lights and again when the main bulb is in use.

**Emergency starting.** An EMERGENCY starting position is provided in the ignition switch for use if the battery has become discharged. Under these conditions, the alternator is connected direct to the ignition coil, allowing the engine to be started independently of the battery.

Once the engine is running, turn the ignition switch back to the normal running position, otherwise misfiring will occur.

**Emergency charging.** Should the battery become discharged a temporary boost can be effected during daylight running, by an alteration to the alternator connections.

The snap connectors are located behind the frame plate, which is se-



cured by two knurled screws.

- (1) Disconnect the green and yellow and green and black connectors.
- (2) Reconnect the green and black to the green and yellow.
- (3) Do not interfere with the green and white cable.

It is stressed that this is only a temporary measure, prolonged use will adversely affect the battery.

**Rectifier.** The rectifier is a device to allow current to flow in one direction only. It is connected to provide full-wave rectification of the alternator output. The rectifier is mounted on the tool box under the twin seat.

The rectifier requires no maintenance beyond checking that the connections are clean and tight. **The nut clamping the rectifier plates together must not under any circumstances be slackened, as it has been carefully set during manufacture to give correct rectifier performance. A separate nut is used to secure the rectifier to the frame of the motor cycle.**

**NOTE**—It is important to check periodically that the rectifier is firmly attached to its mounting bracket.

### LUCAS COIL IGNITION

The coil is clipped to the front frame top tube underneath the petrol tank.

The ignition equipment comprises a model MA6 ignition coil and a model CA1A contact breaker unit. The contact breaker unit, together with an automatic timing control, are located in the engine timing case.

The automatic timing control is centrifugal operated and varies the firing point according to the speed of the engine.

**Lubrication.** To be carried out every 6,000 miles.

**No grease or oil must be allowed to get on or near the contacts when carrying out the following procedure.**

Smear the surface of the cam very lightly with Mobilgrease No. 2, or, if this is not available, clean (SAE 30-40) engine oil may be used.

Squeeze a little grease into the felt wick.

Place a spot of clean engine oil on the contact breaker pivot.

Remove the central fixing bolt and inject a small amount of clean engine oil into the hole thus exposed. When the fixing bolt has been replaced and the engine run for a few minutes, the oil will be forced out over the automatic advance mechanism by centrifugal force.

**Cleaning (every 6,000 miles).** Examine the contact breaker. The contacts must be free from grease or oil. If they are burned or blackened, clean with fine carborundum stone or very fine emery cloth, afterwards wiping away any trace of dirt or metal dust with a clean petrol moistened cloth. Cleaning of the contacts is made easier if the contact breaker lever carrying the moving contact is removed.

To remove the moving contact, unscrew the nut securing the end of the spring and remove the nut, spring washer and bush. Lift the contact breaker lever off its pivot.

**After cleaning, check the contact breaker setting.**

**Contact breaker setting.** The contact breaker gap should be checked after the first 500 miles running and subsequently every 3,000 miles. To

check the gap, turn the engine over slowly until the contacts are seen to be fully open, and insert a feeler gauge between the contacts.

The correct gap setting is 0.014"—0.016".

If the gap is correct, the gauge should be a sliding fit. (Make sure the gauge is clean and oil free before use.)

To adjust the gap, keep the engine in the position giving maximum contact opening and slacken the screws securing the fixed contact plate. Adjust the position of the plate until the gap is set to the thickness of the gauge, and tighten the securing screws.

### MAGNETO MODELS Electrical Equipment

Lucas electrical equipment is fitted and this comprises three independent electrical circuits, as follows:

(1) **IGNITION**—Magneto, High-tension wires, Sparking plug and Cut-out switch.

(2) **CHARGING**—Dynamo compensated voltage control unit and Battery.

(3) **LIGHTING AND ACCESSORIES**—Lamps, Horn, Switches and Wiring.

**To remove contact breaker.** Take out the hexagon-headed screw from the centre of the contact breaker, then pull the assembly off the tapered shaft. When refitting, ensure the projecting key on the assembly engages with the keyway cut in the armature shaft. Incorrect assembly will affect ignition timing.

**Adjustment every 3,000 miles.** Remove the contact breaker cover and turn the engine until the contact points are fully opened. Check the gap with a gauge having a thickness of .012" (spanner 015023 has a gauge of this thickness as an integral part of it). If the setting is correct the gauge should be a sliding fit, but if the gap varies appreciably from the gauge it should be adjusted by releasing the fixed contact plate securing screw and using a screwdriver.

**Cleaning every 5,000 to 6,000 miles.** Take off the contact breaker cover and remove the contact breaker. If the contact points are burned or blackened, clean them with a fine carborundum stone or with very fine emery cloth, and afterwards wipe away any dust or dirt with a petrol-moistened cloth. After replacing the contact breaker check the point gap and, if necessary, re-set it.

Remove the high tension pick-up (held by swinging spring clip), wipe clean and polish with a fine dry cloth. The high tension pick-up brush must move freely in its holder.

If it is dirty, clean with a cloth moistened with petrol.

On the SR-1 magneto fitted to all 1957 Touring models, the contact breaker is exposed by removing the moulded end cover secured with 3 captive screws.

To remove the contact breaker lever, slacken the nut securing the end contact breaker spring which is slotted to permit easy withdrawal of the moving contact lever.

If dirty, oily or burnt, contact points must be cleaned with a fine car-

borundum stone or very fine emery cloth and afterwards wiped with a cloth moistened with petrol.

**Adjustment of contact breaker (Magneto type SR-1).** If and when adjustment is necessary slacken the two screws securing the fixed contact plate and adjust the position of the plate until the gap, when the contacts are fully opened, is set to the thickness of the gauge. The correct gap should be .010" to .012".

### DYNAMO

A LUCAS type E3-N dynamo is fitted. It is anti-clockwise in rotation. The cutting in speed is 1250-1500 r.p.m. at 7 volts and at 1,850 to 2,200 r.p.m. it gives an output of 5 amps at 7 volts. The replacement part number is 20028A. The negative brush is insulated and the positive brush is earthed. The two exterior terminals are marked "D" and "F", indicating the respective terminals for the Positive and Field wires that lead to similarly marked terminals on the Regulator Unit.

**Inspect commutator and brush gear every 5,000 to 6,000 miles.** (Maker's Recommendation.)

**Remove the cover band to inspect commutator and brush gear.**

The brushes are held in contact with the commutator by means of springs. Move each brush, see they are free to slide in their holders, if dirty, or if sticking, remove and clean with a cloth moistened with petrol. Take care to replace brushes in their original positions, otherwise they will not "bed" properly on the commutator.

If, after long service, the brushes have become worn to such an extent that the brush flexible wire is exposed on the running face, or if the brushes do not make good contact with the commutator, they must be replaced by genuine LUCAS brushes.

The commutator must be free from any trace of oil or dirt and should have a highly polished appearance. Clean a dirty, or blackened, commutator by pressing a fine dry cloth against it while the engine is slowly turned over by means of the kick-starter. (It is an advantage to remove the sparking plug before doing this.) If the commutator is very dirty, moisten the cloth with petrol.

At every 10,000 miles, the complete dynamo should be handed to a Lucas Service Station for dismantling, replacement of worn parts, cleaning and lubrication.

Electrical breakdown of the dynamo is most unusual and therefore before assuming this unit is defective, it should be tested as follows:

Check that the dynamo, regulator and battery are correctly connected.

**Test dynamo in position by:**

(a) Remove the two wires from the dynamo terminals and connect the two terminals with a short length of wire.

(b) Start the engine and set to run at normal idling speed.

(c) Connect the negative lead of a moving coil voltmeter (calibrated not less than 0 to 10 volts) to either of the two dynamo terminals and connect the positive lead to a good earth point on the dynamo or engine.

(d) Gradually increase the engine speed, when the voltmeter reading should rapidly rise and without fluctuation.

Do not allow the voltmeter reading to rise above 10 volts.

Do not race the engine in an attempt to increase the voltage. It is sufficient to run up the engine to a speed of 1,000 r.p.m.

If the above reading is obtained the dynamo is in order.

If there is no reading, check the brush gear.

If there is a low reading of approximately  $\frac{1}{2}$  volt, the field winding may be at fault.

If there is a low reading approximately  $1\frac{1}{2}$  to 2 volts, the armature winding may be at fault.

If the tests, mentioned above clearly indicate the dynamo is not charging, it is then desirable to remove the dynamo from the machine in order to make further tests and repairs or replacements.

**To remove the dynamo (before 1957).**

Remove the left side foot rest arm.

Place a tray under primary chaincase to catch the oil.

Remove chaincase band binding screw and remove metal band and also endless rubber band.

Remove nut and washer in centre of chaincase when outer half can be taken away.

Remove spring circlip, locking plate and nut securing dynamo sprocket and withdraw sprocket with a suitable tool. (Use spanner 017254 to hold sprocket while nut is being slackened, this relieves the dynamo shaft of all bending strain.)

Detach dynamo cables and loosen dynamo clamping bolt to fullest extent.

Twist dynamo by hand until the locating strip on its body is in line with the keyway cutaway in the rear engine plate housing the dynamo, in which position same can be withdrawn tilting upwards to clear gear box while doing so.

To re-fit the dynamo, reverse the foregoing taking care to accurately locate the dynamo sprocket key when applying the sprocket. See separate instructions for correct dynamo chain adjustment and re-fitting outer half of chaincase. Ensure that dynamo sprocket securing nut is well tightened before refitting locking plate and retaining circlip.

### A.V.C. UNIT

Although the voltage regulator and the cut-out are combined structurally, they are electrically separate.

The regulator is set to maintain a pre-determined generator voltage at all speeds and regulates the output of the dynamo to the battery according to the state of charge of the battery. The charge rate is at its maximum when the battery is discharged, automatically tapering off to a minimum as the battery becomes charged and its voltage rises.

Normally, during day-time running, when the battery is in good condition, the dynamo gives only a trickle charge, so that the ammeter reading will seldom exceed 1 to 2 amperes, i.e. half to one division on scale. The cut-out is an automatic switch which is connected between the dynamo and the battery. When the engine is running fast enough to cause the voltage of the dynamo to exceed that of the battery the cut-out allows the

battery to be charged by the dynamo. On the other hand, when the engine speed is low, or the engine is stationary, the cut-out disconnects the battery from the dynamo, thereby preventing current flowing back from the battery to the dynamo, a proceeding that would soon cause the battery to become completely discharged.

The regulator and cut-out are accurately set during manufacture. If, under normal running conditions, it is found that the battery is continually in a low state of charge, or is being constantly over-charged, then the regulator setting should be checked by a qualified electrician and, if necessary, re-set. Whenever possible, this should be carried out by a Lucas Service Depot or Agent.

The A.V.C. Unit is retained by two bolts with self-locking nuts. The self locking nature of the nuts prevents subsequent slacking off. The four terminals of the A.V.C. Unit are plainly marked by the letters F.A.D.E. Wires from F and D go to similarly marked terminals on the dynamo. The A terminal is connected to one of the ammeter terminals and the E terminal is "earthed".

We specially warn against unskilled meddling with the settings of the regulator and the cut-out contacts.

Later machines may be fitted with a new A.V.C. Unit type RB-107, but the foregoing notes will still apply with the exception of terminal grouping which will be F.A.E.D.

**To remove control box (after 1957).** The A.V.C. unit is held in sponge rubber and housed in a partition at the rear top corner of the tool box. To remove it, open the box lid, grasp the unit between the fingers and thumb of one hand, and gently and firmly pull it out. Re-fit with cover outwards.

The four terminals of the control box are plainly marked by the letters D.E.A.F. Wires from F and D go to similarly marked terminals on the dynamo. The A terminal is connected to one of the ammeter terminals and the E terminal is 'earthed'.

**Battery—All Models (MLZ9E).** A lead-acid battery Lucas type is used on all models.

The voltage is 6, the capacity is 12 ampere hours, at the 10 hour rate.

Machines are issued with dry charged batteries, the acid is filled by the dealer.

All models have the POSITIVE battery terminal connected to 'EARTH'.

To remove the head lamp rim, release the screw retaining the lamp rim with one hand and support the light unit with the other.

The light unit can then be taken off the lamp.

**To refit.** Engage bottom tag on lamp rim with the small slit in the shell and gently force the top of the rim back into the shell, after which retighten the retaining screw on the top of the lamp body.

The main bulb is secured by a bayonet fixing holder which is removed by turning anti-clockwise.

The pilot bulb is a plug-in or push fit.

The headlamp rim is detachable from the light unit by removing six spring clips.

#### Main bulb

Home Models	...	...	Lucas No. 373	6-volt
			30/24 watt prefocus	(left hand dip).
General Export Models	...	...	Lucas No. 312	6-volt
			30/24 watt prefocus	(vertical dip).
Continental Models	...	...	Lucas No. 403	6-volt
			35/35 watt prefocus	duplo (vertical dip).
French Export Models	...	...	Lucas No. 379	6-volt
			36/36 watt 3-pin	duplo (vertical dip).
Parking Bulb	...	...	Lucas No. 988	3-watt M.C.C.

**Setting.** The headlamp should be set so that when the machine is carrying its normal load the driving beam is projected straight ahead and is parallel with the road surface.

**Dipper switch.** Every 5,000 miles the moving parts of the dipper switch should be lubricated with thin machine oil.

**Headlamp (Alternator Models).** A separate ignition switch is incorporated in the right side of the headlamp body.

**Lucas stop tail lamp (Model 564).** The correct size of bulb to be used in rear lamps is based on the cubic capacity of the engine. The replacement bulb for this lamp is Lucas No. 384, 6-volt, 6/18 watt. Small bayonet cap.

**Lucas horn (Model HF 1441).** Horns are pre-set to give their best performance and, in general, no further adjustment is necessary.

If the horn becomes uncertain in its action, giving only a choking sound, or does not vibrate, it does not follow that the horn has broken down—the trouble may be due to a discharged battery, a loose connection, or short-circuit in the wiring of the horn.

In particular ascertain that the horn-push bracket is in good electrical contact with the handlebars.

It is also possible that the performance of a horn may be upset by its mounting becoming loose.

#### ALTERNATOR Model RM15

The following data applies to three versions of Model RM15, namely, 540, 210, 18, fitted to magneto ignition machines, 047, 534, fitted to coil ignition machines, and 540, 210, 05, fitted to two-way radio equipped machines.

#### Test equipment required.

- (1) First-grade moving coil a.c. voltmeter. 0-20 volts.
- (2) First-grade moving coil d.c. ammeter. 0-25 amps.
- (3) One ohm load resistor (capable of carrying 20 amperes without overheating).

**Test No. 1.** For this test, the battery must be in good condition and more than half charged.

(1) Connect the d.c. ammeter between the battery negative terminal and the battery main cable.

(2) Start the engine and set it to run at approximately 3,000 r.p.m.

(3) Observe the ammeter readings in each of the positions of the lighting switch.

The figures given in the following table are the minimum acceptable battery input currents. If the readings obtained are lower than the figures quoted, proceed to Test No. 2.

<i>Minimum acceptable battery charging currents.</i>				
<i>Switch Position</i>	<i>Despatch number of unit.</i>			
	540, 210, 18	047, 534	540, 210, 05	
			<i>Boost switch Open</i>	<i>Boost switch Closed</i>
Off ...	2.75	2.5	4.0	9.0
Parking	2.0	1.5	2.5	7.0
Head ...	2.0	2.5	3.5	3.5

<i>Minimum acceptable voltage readings.</i>			
<i>Voltmeter and Resistor connected between</i>	<i>Despatch number of unit.</i>		
	540, 210, 18	047, 534	540, 210, 05
White-with-Green and Green-with-Black cables	4.0	4.0	9.5
White-with-Green and Green-with-Yellow cables	6.5	6.5	13.0
White-with-Green and Green-with-Black (with Green-with-Yellow connected to Green-with-Black)	8.5	9.0	15.5
Each cable in turn and earth	Zero	Zero	Zero

Unsatisfactory readings can be due to defective wiring or connections. Ensure that all snap-connector joints and earth connections are in good condition before proceeding to Test No. 2.

If considered necessary, check the rectifier by substitution.

- (1) Disconnect the three alternator output cables.
- (2) Start the engine and set to run at approximately 3,000 r.p.m.
- (3) Connect the one ohm load resistance in parallel with the a.c. voltmeter and check the voltage between the alternator output cables.
- (4) Conclusions to be drawn from results of above tests:
  - Demagnetised rotor magnets indicated by all readings being low.
  - Short-circuited coil indicated by individual reading being low.
  - Open-circuited coil or coils indicated by zero reading(s).
  - Earthed coil or coils indicated by voltage reading between any output cable and earth.

Alternator, Model RM15, with rotor, withdrawn (REC 728).

### CONDENSER CHECK

When investigating a misfire, and where the condenser is suspect, the use of an external condenser will prove if this component is defective.

Use a sound condenser with two crocodile clips attached.

Attach one clip to the low tension terminal on the distributor, the other to a convenient earth position.

A short test, by running the engine, will indicate if the condenser is defective.

In the case of Single Cylinder Models, remove contact breaker cover, fit one clip to terminal for contact breaker pivot post, the other to earth.

### CHECKING THE RECTIFIER

If a spare rectifier known to be in good condition is available, the simplest check is that of substitution. (In this connection, Lucas rectifier 47132 is used with alternators 540, 210, 18 and 047, 534, while rectifier 47142 is used in conjunction with alternator 540, 210, 05.)

When a satisfactory substitute is not available, the rectifier is best checked by removing it from the machine and bench testing it.

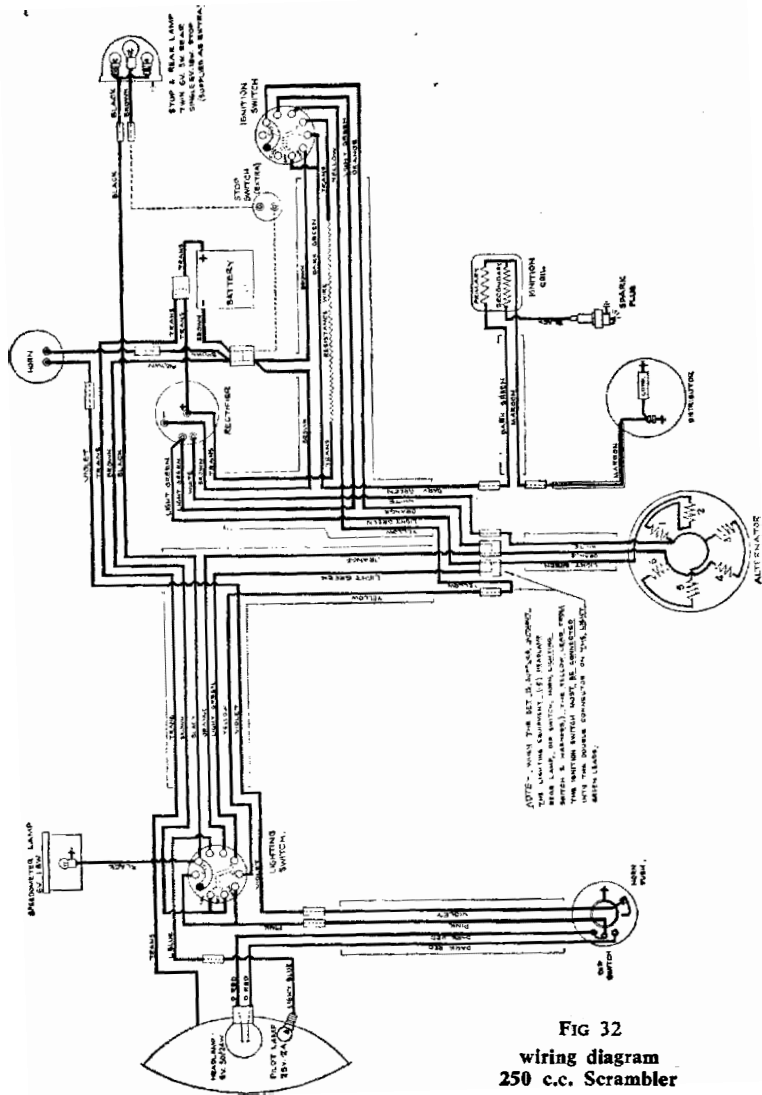

120

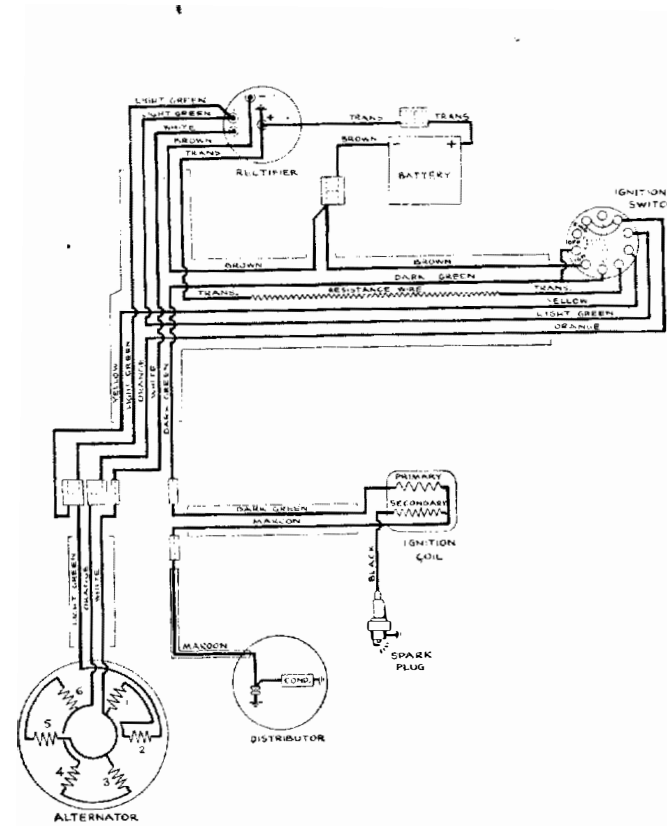

121

